

RASCAL BEGINNER TRAINING

Sam Hanson, PhD

April 27, 2026

0930 ET

RASCAL TEAM

RAMP

U.S. NRC Office of Regulatory Research (RES)

RASCAL Primary User

U.S. NRC Office of Nuclear Security and Incident Response (NSIR)

Rigel Flora

Health Physicist, RASCAL Project Manager

Sam Edwards

Computer Scientist, RASCAL 5 Dev Lead

Stephanie Bush-Goddard, PhD

RAMP Founder

Brian Allen

Future RAMP Manager

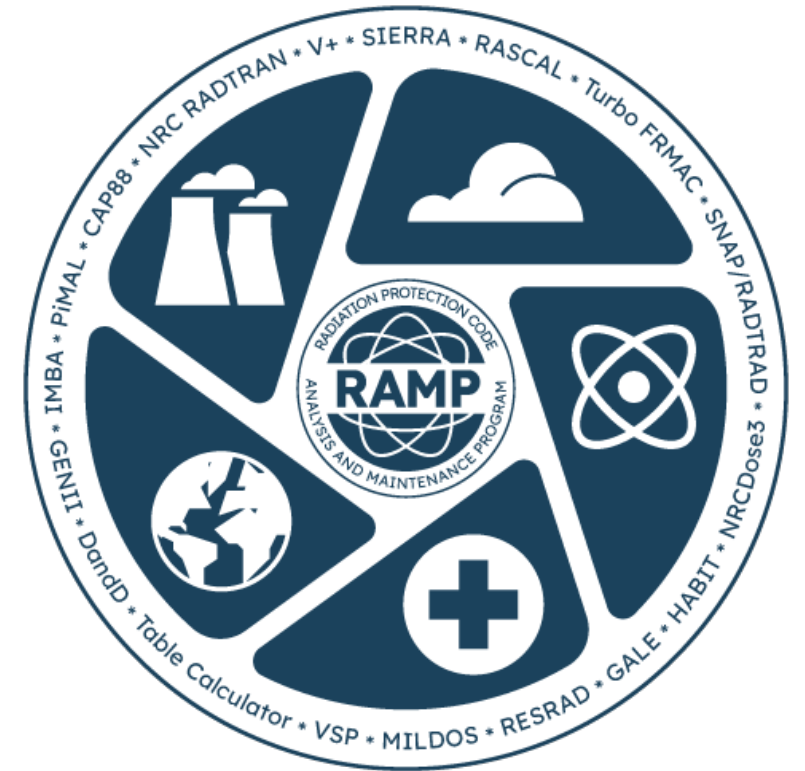

TRAINING AND SUPPORT AT RAMP.NRC-GATEWAY.GOV

- **Need Account to Access**
 - **Non-Disclosure Agreement (NDA)**
 - **Fed/State/Local/International/Private**
- **Code Distribution**
- **Technical Support**
 - **Technical documentation (NUREGs)**
 - **Training**
 - **Git Migration**

RAMP Website
Radiation Protection Computer Code
Analysis and Maintenance Program

CODES + MEMBERSHIP + MEETINGS + PARTNERS ABOUT +

Home > Download RASCAL > Download RASCAL

Code Menu

- RASCAL Overview
- Download
- Documentation
- Training
- FAQs
- Forum
- Request Support
- Manage Group
- Get Access to this Code

Download RASCAL

View Edit Delete Entityqueue Clone Scheduled transitions (0) Clone

Requirements

- RASCAL 4.3.4 requires .NET Core 3.1 for installation, you can check for it in your OS by typing in your command prompt: `dotnet --list-runtimes`
- .NET Core 3.1 can be downloaded [online from Microsoft](#).
- RASCAL 4.3.4 is primarily designed to run under Windows 10, but also works on Windows 11.
- The installation must be run with administrative rights and will require 80 MB of disk space.
- RASCAL 4.3.4 should be run **only** with the Windows Regional and Language Options set to **English (United States)**.

RASCAL RESOURCES

- NUREG-1887 for RASCAL 3
- NUREG-1940 for RASCAL 4
- NUREG-1465 for LOCA
- SOARCA for SBO
- EPA PAGs (latest 2017)
- Aviationweather.gov for meteorology (U.S. NOAA)

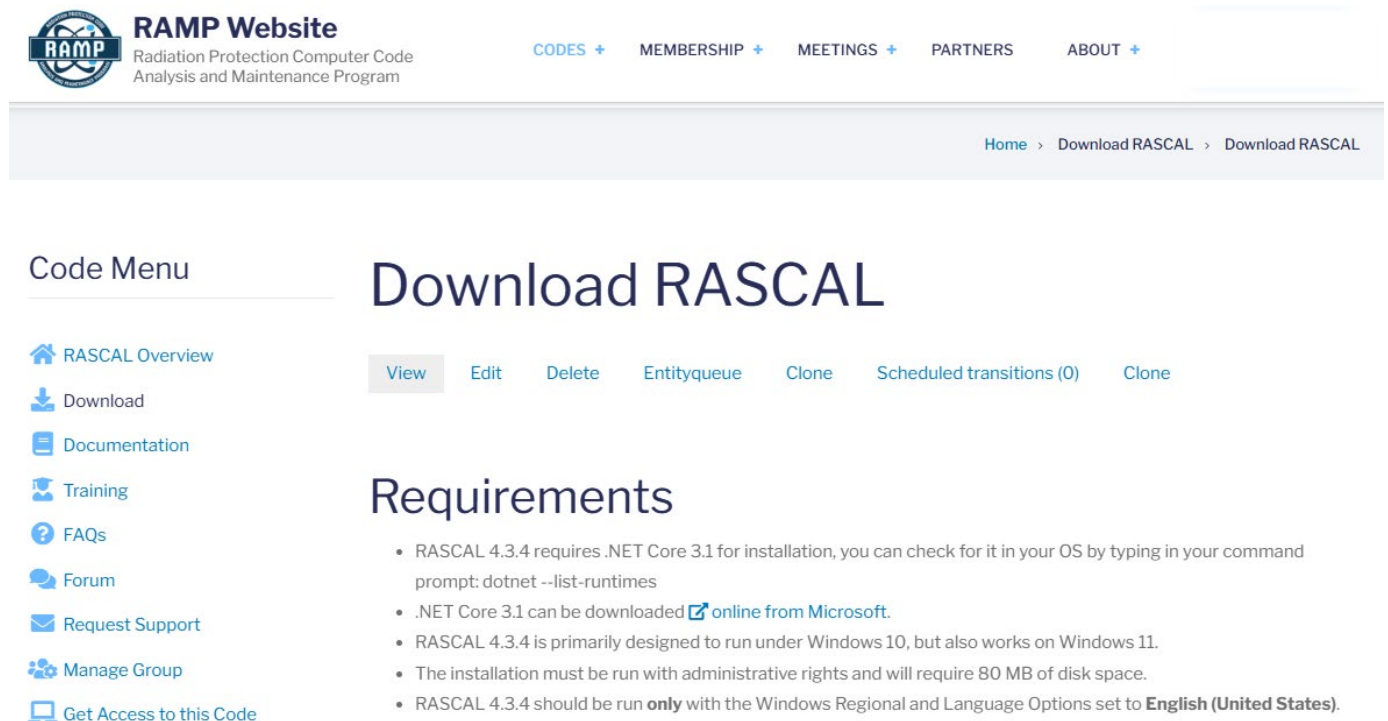

The screenshot shows the RAMP Website interface. At the top left is the RAMP logo and the text "RAMP Website Radiation Protection Computer Code Analysis and Maintenance Program". To the right are navigation links: "CODES +", "MEMBERSHIP +", "MEETINGS +", "PARTNERS", and "ABOUT +". Below this is a breadcrumb trail: "Home > Download RASCAL > Download RASCAL".

On the left side, there is a "Code Menu" with the following items:

- RASCAL Overview
- Download
- Documentation
- Training
- FAQs
- Forum
- Request Support
- Manage Group
- Get Access to this Code

The main content area features a large heading "Download RASCAL" with a sub-menu containing: "View", "Edit", "Delete", "Entityqueue", "Clone", "Scheduled transitions (0)", and "Clone". Below this is a "Requirements" section with the following list:

- RASCAL 4.3.4 requires .NET Core 3.1 for installation, you can check for it in your OS by typing in your command prompt: `dotnet --list-runtimes`
- .NET Core 3.1 can be downloaded [online from Microsoft](#).
- RASCAL 4.3.4 is primarily designed to run under Windows 10, but also works on Windows 11.
- The installation must be run with administrative rights and will require 80 MB of disk space.
- RASCAL 4.3.4 should be run **only** with the Windows Regional and Language Options set to **English (United States)**.

RASCAL SLIDE

- Every time we ask you to use RASCAL, you'll see one of these blue slides.
- It will include information needed to complete the steps.



TECHNOLOGY REVIEW



**Nuclear Power
Plant**



Spent Fuel



Fuel Cycle



Other Material

REACTOR TYPES

Core inside reactor vessel creates heat, steam is created (main loop in BWR, secondary loop in PWR), steam turns turbine, which produces electricity

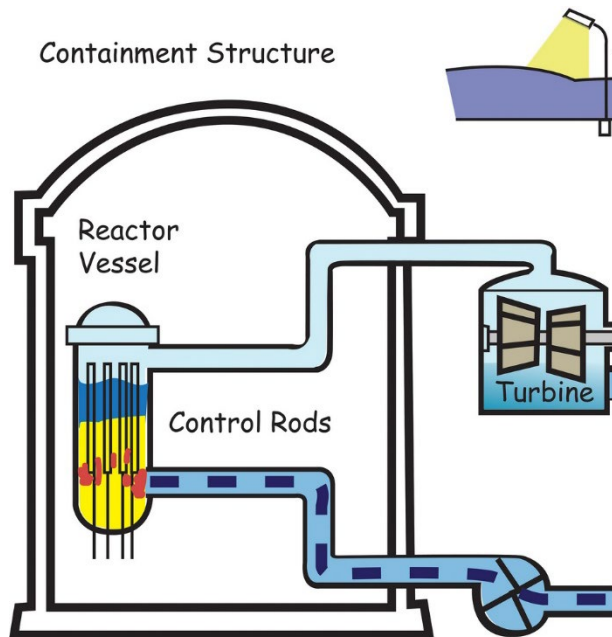

Boiling Water Reactor (BWR)

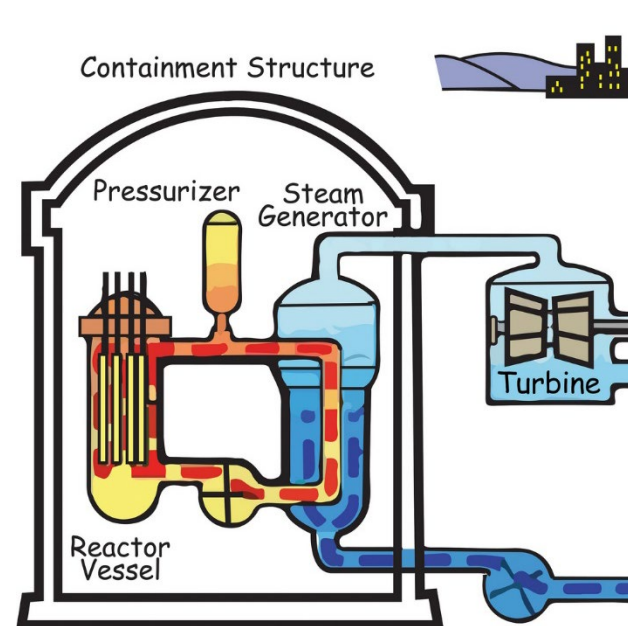

Pressurized Water Reactor (PWR)

LARGE RELEASES WILL COME FROM MAJOR FUEL DAMAGE, ONLY CAUSED FROM LACK OF COOLING

- No heat removal leads to fuel cladding failure and fuel melt
- Eventual RCS overpressure / leakage
- Possible containment overpressure / leakage
- Defense in Depth

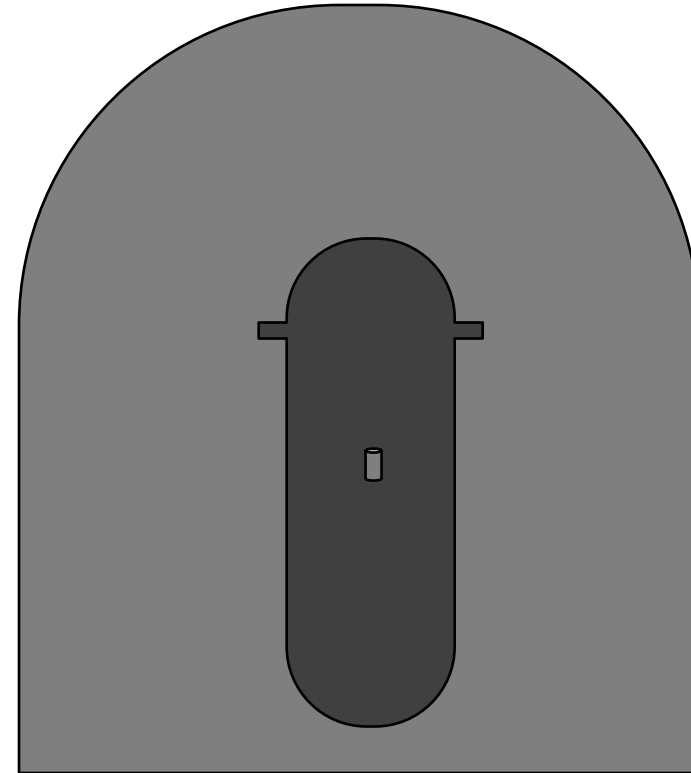

SPENT FUEL

- Every 12-24 months, a fraction of reactor core is replaced and moved to a pool to cool.
- 5-10 years later, cooler fuel moved to dry cask

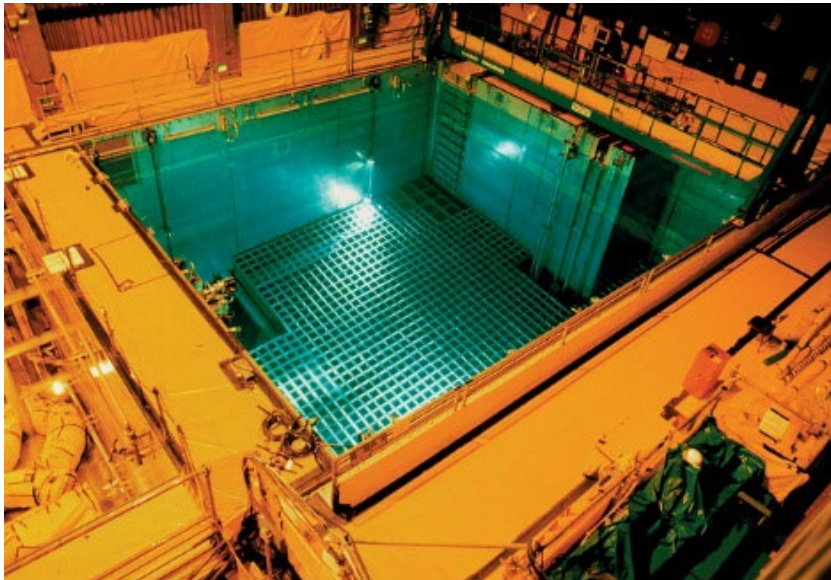

FUEL CYCLE

- **Fuel cycle facilities convert, enrich, and fabricate mined material into reactor fuel**
- **RASCAL Supports these accident types:**
 - **UF₆ Cylinders**
 - **Criticality**
 - **Fire/Explosions involving Uranium Oxide**

THERE ARE 4 PRIMARY TOOLS AND 3 ADDITIONAL TOOLS ON THE RASCAL HOME PAGE.

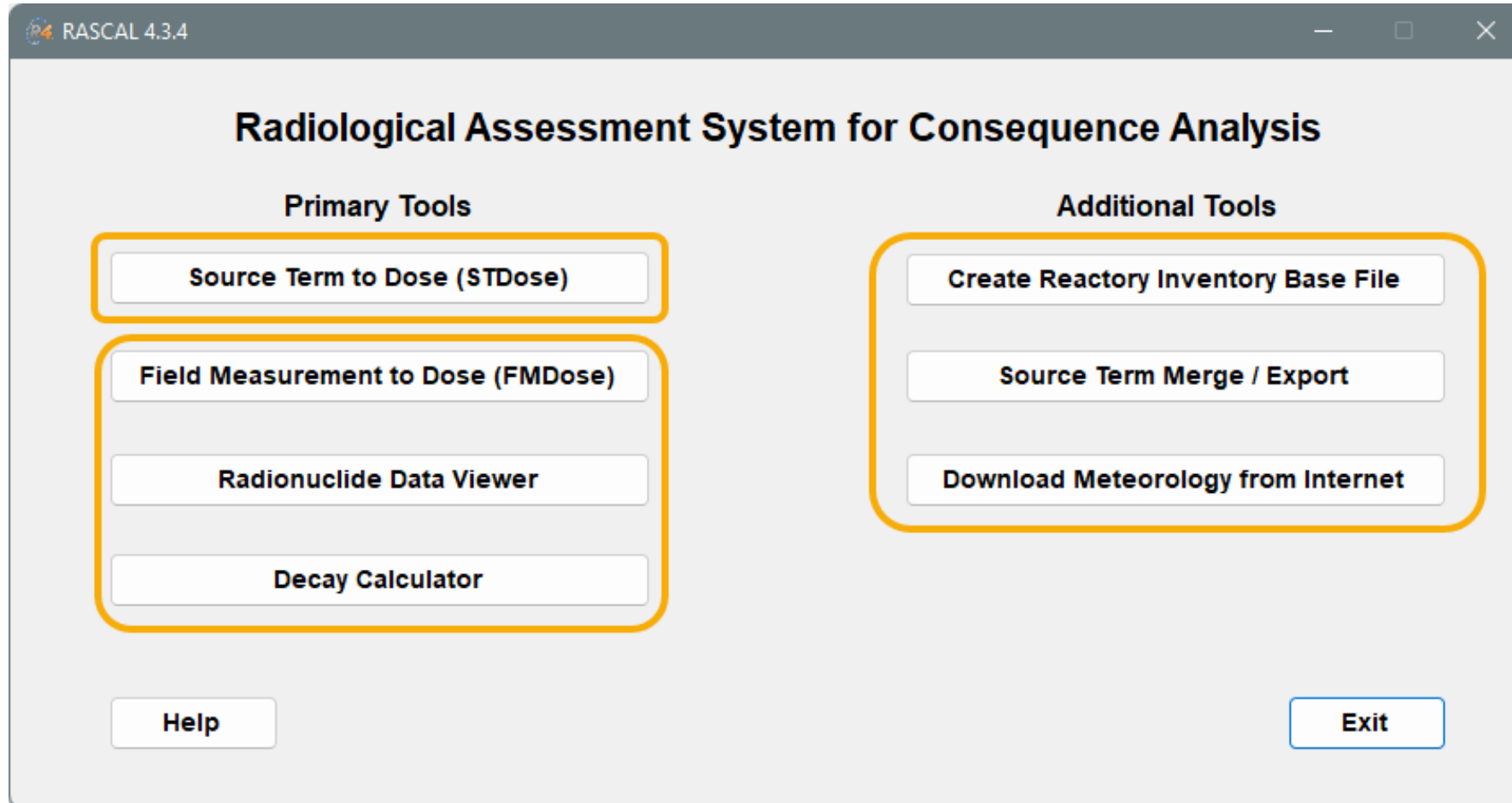

WHERE DOES RASCAL FIT IN THE PHASES OF A RADIOLOGICAL EMERGENCY?

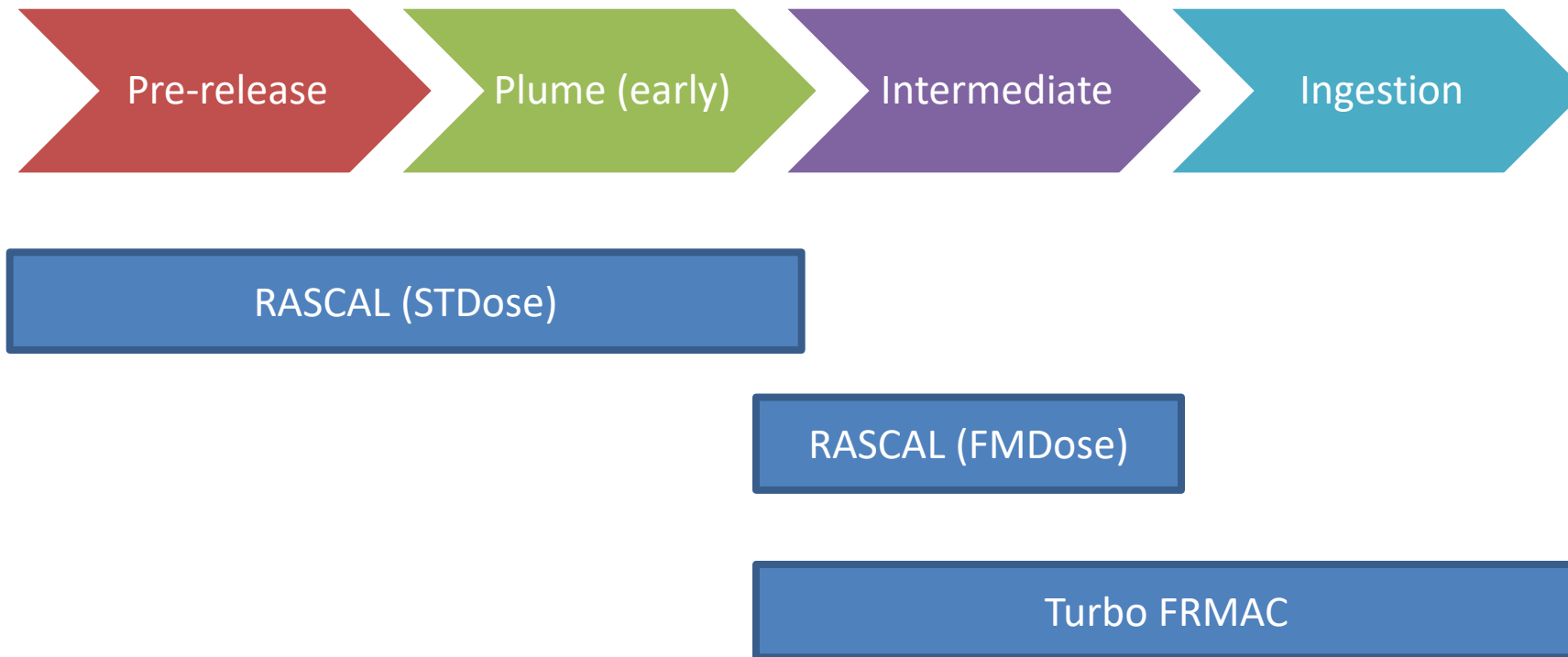

OUR TRAINING WILL FOCUS ON STDose

Source Term to Dose module creates an atmospheric source term from a core and release pathway, processes weather data, and calculates doses.

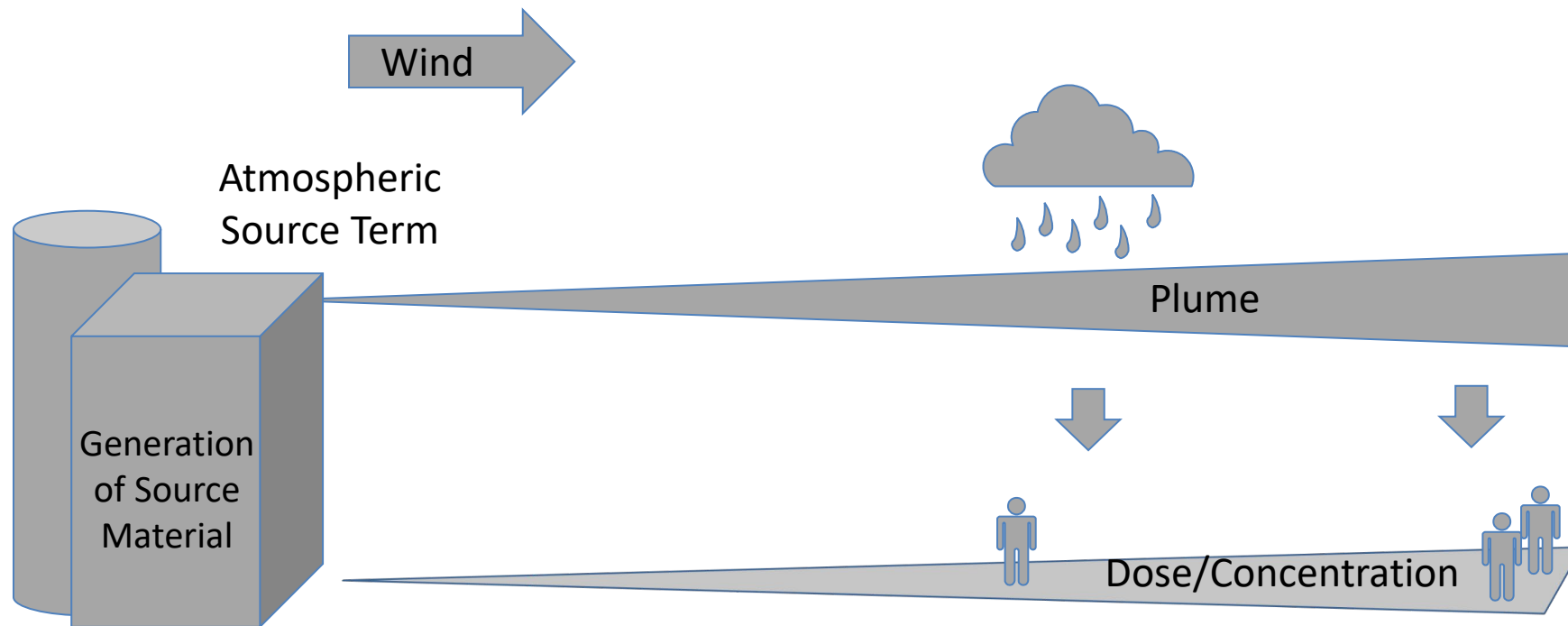

RASCAL DEFINES ATMOSPHERIC SOURCE TERM

- **Determines radionuclides available for release**
 - May be single nuclide or complex core damage
 - Time-dependent isotopes and activity
- **Source material may be filtered, reduced, or decayed**

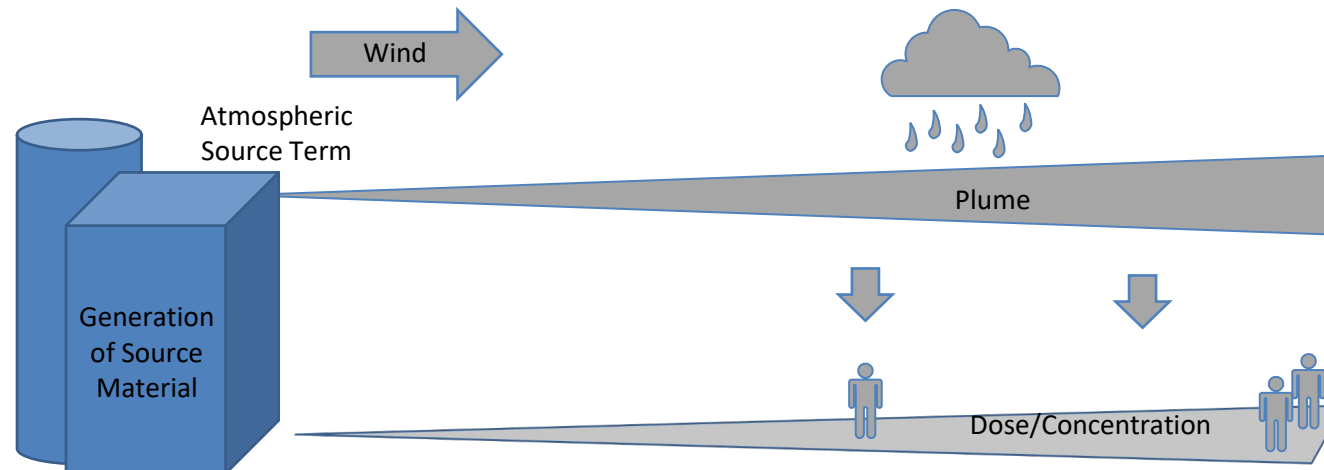

RESULT IS RADIONUCLIDES RELEASED TO ENVIRONMENT OVER TIME (ATMOSPHERIC SOURCE TERM)

Isotopic activity over time (15 min)

Activity (Ci) released to atmosphere (by nuclide and time step)

Interval	2025/01/30 11:15	2025/01/30 11:30	2025/01/30 11:45	2025/01/30 12:00	2025/01/30 12:15	2025/01/30 12:30	2025/01/30 12:45	2025/01/30 13:00
Ba-139	0.00E+00	0.00E+00	0.00E+00	3.90E-04	3.31E-04	2.81E-04	2.38E-04	2.02E-04
Ba-140	0.00E+00	0.00E+00	0.00E+00	6.51E+01	6.26E+01	6.02E+01	5.79E+01	5.56E+01
Cs-134	0.00E+00	0.00E+00	0.00E+00	3.02E+02	2.92E+02	2.80E+02	2.69E+02	2.58E+02
Cs-136	0.00E+00	0.00E+00	0.00E+00	1.17E+02	1.13E+02	1.08E+02	1.04E+02	1.00E+02
Cs-137*	0.00E+00	0.00E+00	0.00E+00	2.10E+02	2.02E+02	1.94E+02	1.86E+02	1.78E+02
Cs-138	0.00E+00	0.00E+00	0.00E+00	1.08E-10	7.52E-11	5.24E-11	3.65E-11	2.56E-11
I-131	0.00E+00	0.00E+00	0.00E+00	2.12E+03	2.04E+03	1.96E+03	1.89E+03	1.81E+03
I-132	0.00E+00	0.00E+00	0.00E+00	2.72E+03	2.61E+03	2.50E+03	2.40E+03	2.30E+03
I-133	0.00E+00	0.00E+00	0.00E+00	2.08E+03	1.99E+03	1.89E+03	1.81E+03	1.72E+03
I-134	0.00E+00	0.00E+00	0.00E+00	2.89E-05	2.28E-05	1.80E-05	1.42E-05	1.04E-05
I-135	0.00E+00	0.00E+00	0.00E+00	3.56E+02	3.34E+02	3.12E+02	2.93E+02	2.74E+02
Kr-83m	0.00E+00	0.00E+00	0.00E+00	1.01E+00	9.18E-01	8.33E-01	7.57E-01	6.81E-01
Kr-85	0.00E+00	0.00E+00	0.00E+00	6.31E+02	6.30E+02	6.29E+02	6.28E+02	6.27E+02
Kr-85m	0.00E+00	0.00E+00	0.00E+00	4.42E+02	4.25E+02	4.09E+02	3.92E+02	3.75E+02
Kr-87	0.00E+00	0.00E+00	0.00E+00	7.51E-02	6.54E-02	5.70E-02	4.97E-02	4.24E-02
Kr-88	0.00E+00	0.00E+00	0.00E+00	1.40E+02	1.31E+02	1.23E+02	1.15E+02	1.07E+02
La-140	0.00E+00	0.00E+00	0.00E+00	1.34E+01	1.31E+01	1.29E+01	1.26E+01	1.23E+01
Mo-99	0.00E+00	0.00E+00	0.00E+00	8.54E+02	8.20E+02	7.87E+02	7.55E+02	7.23E+02
Rb-86	0.00E+00	0.00E+00	0.00E+00	4.23E+00	4.07E+00	3.91E+00	3.76E+00	3.60E+00

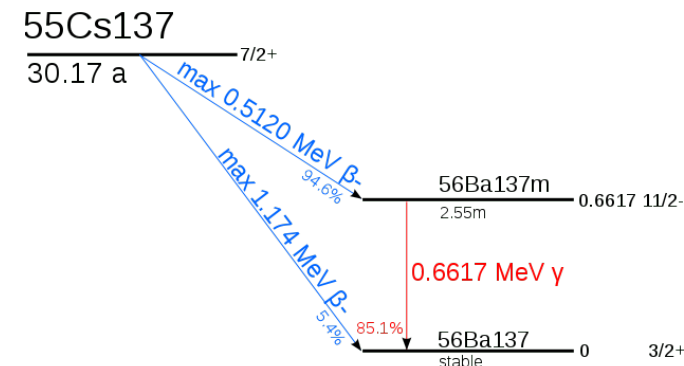
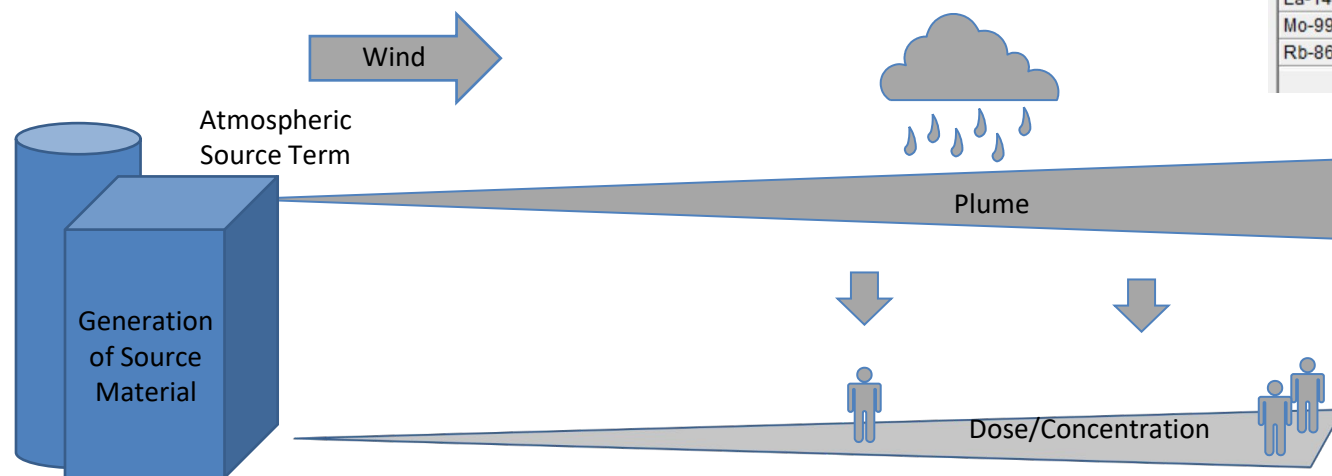

ATMOSPHERIC SOURCE TERM IS MOVED USING ATD MODELS

Atmospheric Transport and Dispersion Models

- Transport material based on weather conditions
- Track material to where it falls/washes on ground
- Accounts for dry/wet processes and particle size

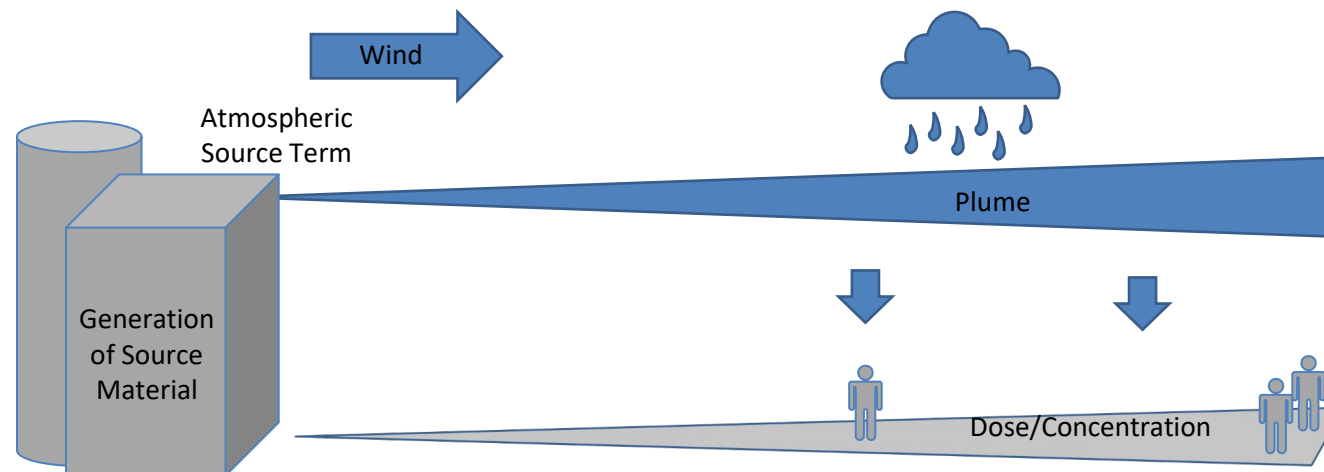

FINAL CALCULATIONS PROVIDE DOSES AND CONCENTRATIONS OVER CALCULATION AREA

- **Dose calculation accounts for multiple pathways**
 - **External (Groundshine + cloudshine)**
 - **Internal (Inhalation + ~~ingestion~~)**
- **Results includes other display/calculation options**

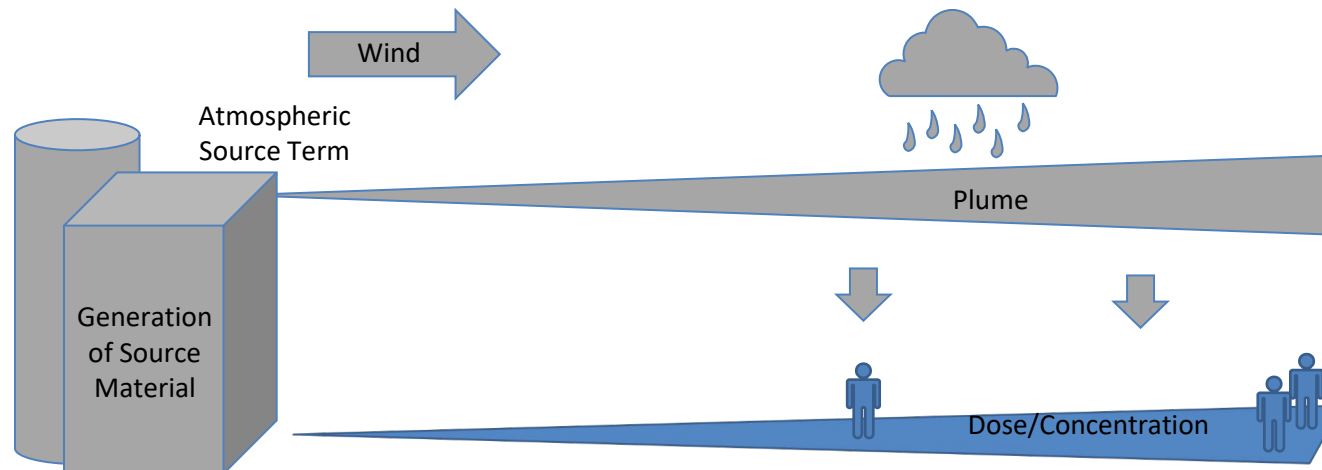

WALKTHROUGH

Radiological Assessment System
for Consequence Analysis

RASCAL 4.3.4

January 2022

U.S. Nuclear Regulatory Commission

For more information visit: ramp.nrc-gateway.gov

Continue

This computer program was created as work sponsored by an agency of the United States Government. Neither the United States Government nor any agency thereof, nor its contractors, nor any of their employees, makes any warranty, expressed or implied, or assumes any legal liability or responsibility for any third party's use, or the results of such use, or of any information in or generated by this program, or represents that its use by such third party would not infringe privately-owned rights. In addition you may not distribute this computer program or use this computer program without the permission of the U.S. Nuclear Regulatory Commission.

Let's step through a RASCAL run together

- Watch our discussion slides without using your RASCAL (screenshots may not match)
- At each blue slide, you will input information into RASCAL

SELECT STDose

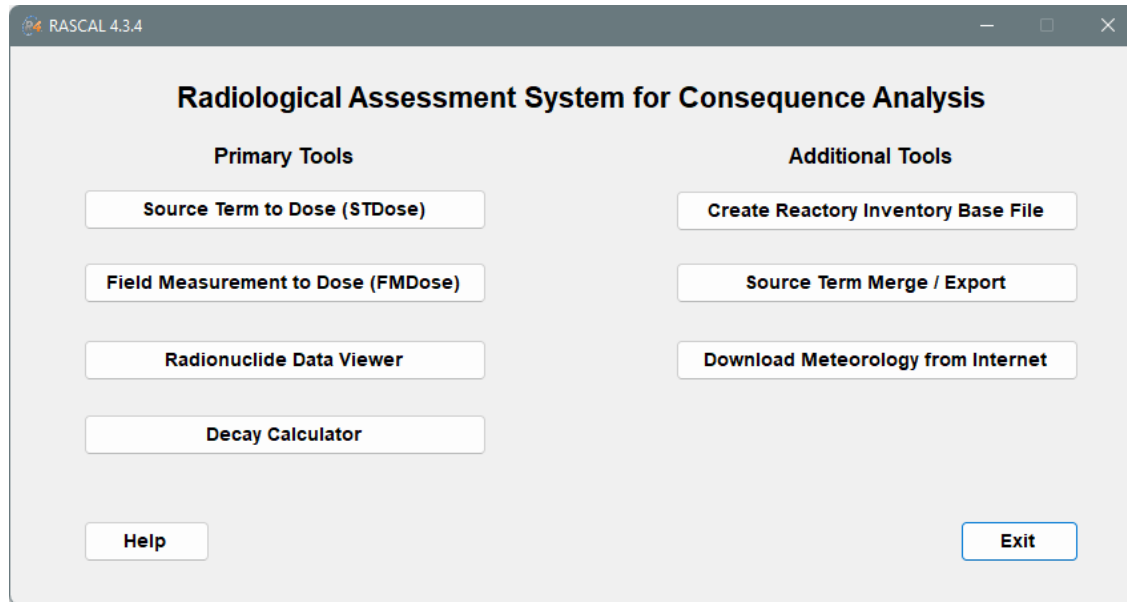

Most of what you will be using RASCAL for (dose assessment) will be done with Source Term to Dose (STDose).

USING STDOSE

The screenshot displays the STDOSE software interface. On the left is a vertical column of input fields, each with a yellow button and a placeholder text '<undefined>'. From top to bottom, these are: 'Event Type' (with a help icon), 'Event Location', 'Source Term', 'Import' (with an unchecked checkbox), 'Release Path', 'Meteorology', 'Calculate Doses', and 'Detailed Results'. On the right is a 'Case Summary' table with the following entries:

Case Summary	
Event Type	Undefined
Case description	Available after calculations completed
Source Term	Undefined
Release Pathway	Undefined
Meteorology	Undefined

- Input information on the buttons on left, from top to bottom
 - Meteorology can be input once a location is selected
- Translate available data into RASCAL inputs
 - Some data is “static”; enter once
 - Some data is “dynamic” and changes with time as more communications are established and as conditions evolve

START BY CLICKING EVENT TYPE

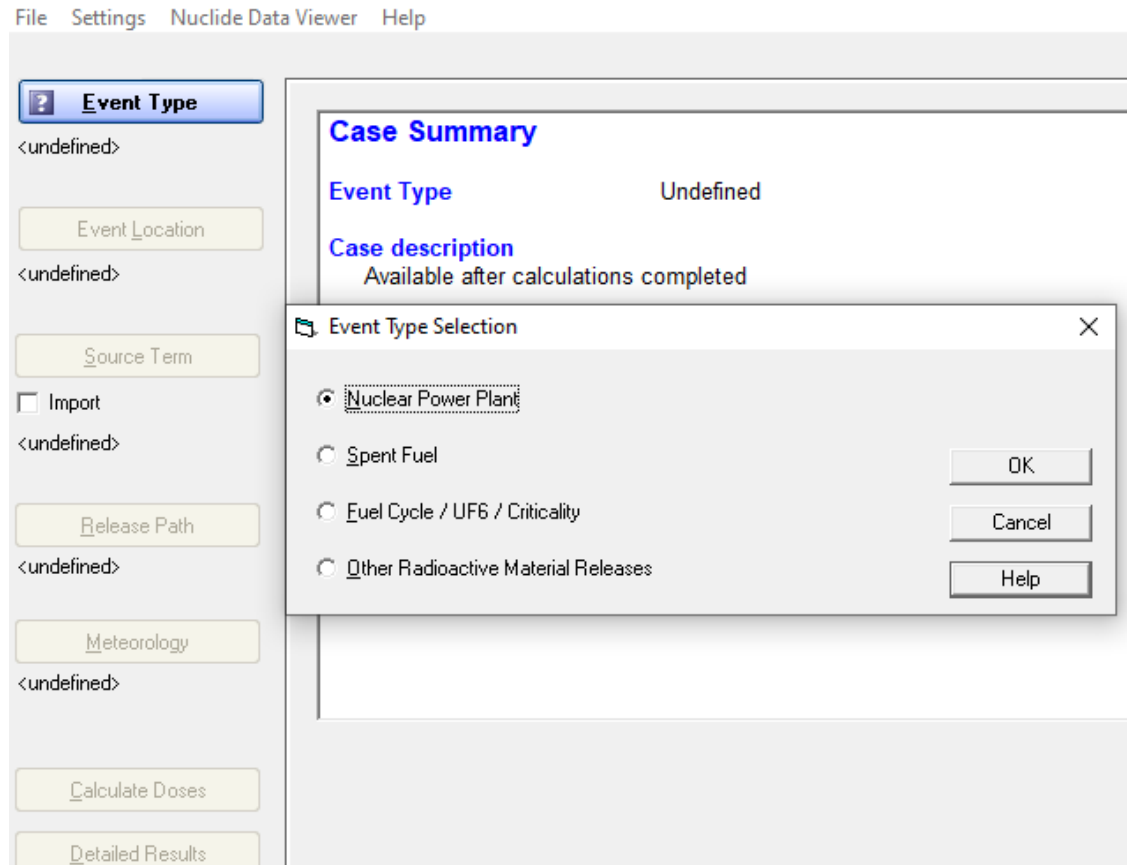

RASCAL breaks up locations and models into 4 types:

- NPP
- Spent Fuel
- Fuel Cycle
- Other/Materials

NEXT, CLICK EVENT LOCATION

Location and Plant Parameters of Nuclear Power Plant

Load Existing Nuclear Power Plant Site from Database
 Define a "Generic" Nuclear Power Plant Site

List only these sites: Site names:

Reactor power: MWt
Average burnup - in reactor: MWd/MTU
Discharge burnup - in spent fuel storage: MWd/MTU

- Select from a list of predefined sites
 - All U.S. facilities (NPPs, Fuel Cycle, Materials)
 - International NPPs including: Mexico, South Africa, Taiwan, and UAE
- Or, define a custom site
 - Need Latitude/Longitude coordinates
 - Does not build in roughness or topography

AT THE BOTTOM OF LOCATION, CHECK REACTOR POWER

Location and Plant Parameters of Nuclear Power Plant

Load Existing Nuclear Power Plant Site from Database
 Define a "Generic" Nuclear Power Plant Site

List only these sites: Site names:

Reactor power: MWt

Average burnup - in reactor: MWd/MTU

Discharge burnup - in spent fuel storage: MWd/MTU

- Units of megawatts thermal (MWt) and is a direct measure of the energy produced by fission. This number is used by the model to determine the fission product inventory in the core.
- The facility database contains the power level at which the reactor is allowed to operate.
- Since reactors generally try to operate at 100% power, this value should rarely be changed.

ALSO CHECK BURNUP

Location and Plant Parameters of Nuclear Power Plant

Load Existing Nuclear Power Plant Site from Database
 Define a "Generic" Nuclear Power Plant Site

List only these sites: Site names:

Reactor power: MWt

Average burnup - in reactor: MWd/MTU

Discharge burnup - in spent fuel storage: MWd/MTU

- Fuel burnup has units of megawatt-days per metric ton of uranium (MWd/MTU) and is a measure of how much fission energy has been produced by the fuel elements that are currently in the core.
- RASCAL uses burnup to adjust core inventory for long-lived radionuclides in the core fuel. A mid-life core value is used as default instead of site-specific values
- If you have a burnup value – use it, otherwise the default is OK.

YOUR TURN TO USE RASCAL

- **Start the RASCAL program & select STDose**
- **Click Event Type**
 - **Select Nuclear Power Plant**
 - **Click OK**
- **Click Event Location**
 - **Select Beaver Valley, Unit 1**
 - **Click OK**



LET'S WALK THROUGH TOGETHER



KNOWLEDGE CHECK



The RASCAL STDose model supports which of the following radiological emergency phases? [select all that apply]

– Pre-release

– Plume (early)

– Intermediate

– Ingestion

T or F, RASCAL can model releases from sites not in its facility database?

– True

– False

SOURCE TERM

- Source term models calculate material that can be released
- Pick the best model; may have multiple options
- Available choices depend on Event Type

Nuclear Power Plant

The screenshot shows a software interface for selecting source term options for a Nuclear Power Plant event. On the left, there is a sidebar with 'Event Type' set to 'NUCLEAR POWER PLANT' and 'Source Term' selected. The main area displays 'Source Term Options for Nuclear Power Pla' and lists two categories: 'Source term based on reactor conditions' and 'Source term based on nuclide specific data'. The 'reactor conditions' category includes options like 'Long Term Station Blackout (SBO/STCA)', 'LOCA (NUREG-1475)', 'Cobalt Release-Accidents', and 'Containment Radion Monit'. The 'nuclide specific data' category includes 'Cobalt Sample', 'Containment Air Sample', 'Effluent Releases - by Volume', 'Effluent Release Rates - by Nuclide', and 'Effluent Release Concentrations - by Nuclide'. A text box on the right states: 'RASCAL has 9 nuclear power plant source term options: 4 based on reactor condition models, 5 based on nuclide measurements'.

Spent Fuel

The screenshot shows a selection interface for 'Source Term Options for Spent Fuel'. It contains three radio button options: 'Pool Storage - Uncovered Fuel', 'Pool Storage - Damaged Assembly Underwater', and 'Dry Storage - Cask Release'.

Fuel Cycle

The screenshot shows a selection interface for 'Source Term Options for Fuel Cycle Event'. It contains seven radio button options: 'UF6 Release from Cylinder(s)', 'Fire Involving Uranium Oxide', 'Criticality Accident', 'Explosion Involving Uranium Oxide', 'Effluent Release Rates - by Nuclide', and 'Effluent Release Concentrations - by Nuclide'.

Other Materials

The screenshot shows a selection interface for 'Source Term Options for Other Rad Mat'. It contains three radio button options: 'Effluent Release Rates - by Nuclide' (which is selected), 'Effluent Release Concentrations - by Nuclide', and 'Sources and Material in a Fire'.

? **Event Type**

NUCLEAR POWER PLANT

? **Source Term**

Source Term Options for Nuclear Power Pla

Source term based on reactor conditions

- Long Term Station Blackout (SOARCA)
- LOCA (NUREG-1465)
- Coolant Release Accidents
- Containment Radiation Monitor

Source term based on nuclide specific data

- Coolant Sample
- Containment Air Sample
- Effluent Releases - by Mixtures
- Effluent Release Rates - by Nuclide
- Effluent Release Concentrations - by Nuclide

RASCAL has 9 nuclear power plant source term options:

- 4 based on reactor condition models
- 5 based on nuclide measurements

SOURCE TERM

- Source term models calculate material that can be released
- Pick the best model; may have multiple options
- Available choices depend on Event Type

Nuclear Power Plant

Source Term Options for Nuclear Power Pla

Source term based on reactor conditions

- Long Term Station Blackout (SQARCA)
- LOCA (NUREG-1465)
- Coolant Release Accidents
- Containment Radiation Monitor

Source term based on nuclide specific data

- Coolant Sample
- Containment Air Sample
- Effluent Releases - by Mixtures
- Effluent Release Rates - by Nuclide
- Effluent Release Concentrations - by Nuclide

Spent Fuel

Event Type SPENT FUEL

Source Term Options for Spent Fuel

- Pool Storage - Uncovered Fuel
- Pool Storage - Damaged Assembly Underwater
- Dry Storage - Cask Release

For Spent Fuel, RASCAL has 3 source term options

- Includes both pool and dry storage
- Sites are collocated with NPPs

Fuel Cycle

Source Term Options for Fuel Cycle Eve

- U_{F6} Release from Cylinder(s)
- Fire Involving Uranium Oxide
- Criticality Accident
- Explosion Involving Uranium Oxide
- Effluent Release Rates - by Nuclide
- Effluent Release Concentrations - by Nuclide

Other Materials

Source Term Options for Other Rad Mat

- Effluent Release Rates - by Nuclide
- Effluent Release Concentrations - by Nuclide
- Sources and Material in a Fire

? **Event Type**

SPENT FUEL

? **Source Term**

Source Term Options for Spent Fuel

- Pool Storage - Uncovered Fuel
- Pool Storage - Damaged Assembly Underwater
- Dry Storage - Cask Release

For Spent Fuel, RASCAL has 3 source term options

- Includes both pool and dry storage
- Sites are collocated with NPPs

SOURCE TERM

- Source term models calculate material that can be released
- Pick the best model; may have multiple options
- Available choices depend on Event Type

Nuclear Power Plant

Source Term Options for Nuclear Power Pla

Source term based on reactor conditions

- Long Term Station Blackout (SDARCA)
- LOCA (NUREG-1465)
- Coolant Release Accidents
- Containment Radiation Monitor

Source term based on nuclide specific data

- Coolant Sample
- Containment Air Sample
- Effluent Releases - by Mixtures
- Effluent Release Rates - by Nuclide
- Effluent Release Concentrations - by Nuclide

Spent Fuel

Source Term Options for Spent Fuel

- Pool Storage - Uncovered Fuel
- Pool Storage - Damaged Assembly Underwater
- Dry Storage - Cask Release

Fuel Cycle

Event Type FUEL CYCLE

Source Term Options for Fuel Cycle Eve

- UFG Release from Cylinder(s)
- Fire Involving Uranium Oxide
- Critically Accident
- Explosion Involving Uranium Oxide
- Effluent Release Rates - by Nuclide
- Effluent Release Concentrations - by Nuclide

Source Term

- RASCAL can model certain events from fuel fabrication facilities
 - UFG chemical models
 - Criticality
 - UO2 Fire/Explosion

Other Materials

Source Term Options for Other Rad Mat

- Effluent Release Rates - by Nuclide
- Effluent Release Concentrations - by Nuclide
- Sources and Material in a Fire

? **Event Type**

FUEL CYCLE

? **Source Term**

Source Term Options for Fuel Cycle Events

- UF6 Release from Cylinder(s)
- Fire Involving Uranium Oxide
- Criticality Accident
- Explosion Involving Uranium Oxide
- Effluent Release Rates - by Nuclide
- Effluent Release Concentrations - by Nuclide

- RASCAL can model certain events from fuel fabrication facilities
 - UF6 chemical models
 - Criticality
 - UO2 Fire/Explosion

SOURCE TERM

- Source term models calculate material that can be released
- Pick the best model; may have multiple options
- Available choices depend on Event Type

Nuclear Power Plant

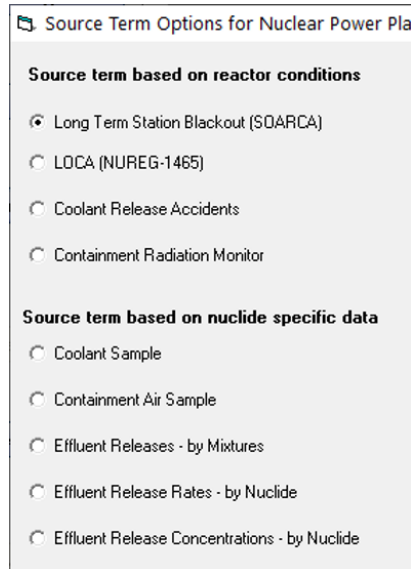

Source Term Options for Nuclear Power Pla

Source term based on reactor conditions

- Long Term Station Blackout (SDARCA)
- LOCA (NUREG-1465)
- Coolant Release Accidents
- Containment Radiation Monitor

Source term based on nuclide specific data

- Coolant Sample
- Containment Air Sample
- Effluent Releases - by Mixtures
- Effluent Release Rates - by Nuclide
- Effluent Release Concentrations - by Nuclide

Spent Fuel

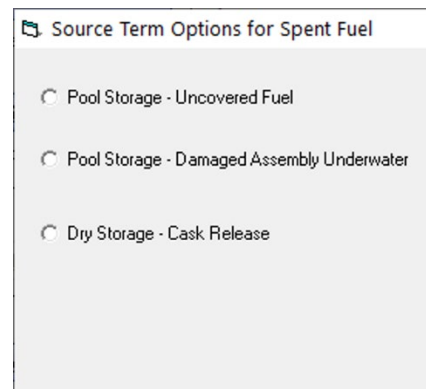

Source Term Options for Spent Fuel

- Pool Storage - Uncovered Fuel
- Pool Storage - Damaged Assembly Underwater
- Dry Storage - Cask Release

Fuel Cycle

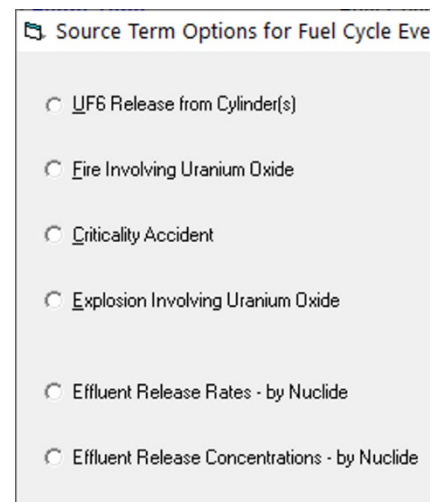

Source Term Options for Fuel Cycle Eve

- U₂₃₅ Release from Cylinder(s)
- Fire Involving Uranium Oxide
- Criticality Accident
- Explosion Involving Uranium Oxide
- Effluent Release Rates - by Nuclide
- Effluent Release Concentrations - by Nuclide

Other Materials

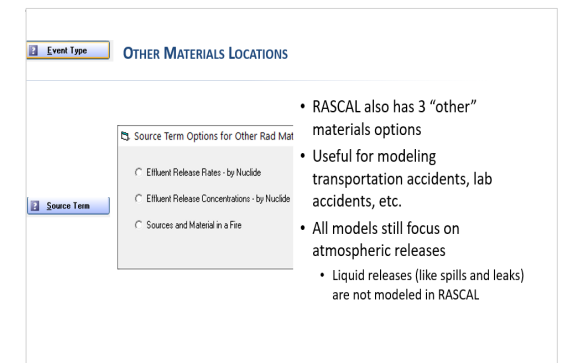

Event Type OTHER MATERIALS LOCATIONS

Source Term

- Effluent Release Rates - by Nuclide
- Effluent Release Concentrations - by Nuclide
- Sources and Material in a Fire

- RASCAL also has 3 "other" materials options
- Useful for modeling transportation accidents, lab accidents, etc.
- All models still focus on atmospheric releases
 - Liquid releases (like spills and leaks) are not modeled in RASCAL

? **Event Type**

OTHER MATERIALS LOCATIONS

? **Source Term**

Source Term Options for Other Rad Mat

- Effluent Release Rates - by Nuclide
- Effluent Release Concentrations - by Nuclide
- Sources and Material in a Fire

- RASCAL also has 3 “other” materials options
- Useful for modeling transportation accidents, lab accidents, etc.
- All models still focus on atmospheric releases
 - Liquid releases (like spills and leaks) are not modeled in RASCAL

SOURCE TERM

- Source term models calculate material that can be released
- Pick the best model; may have multiple options
- Available choices depend on Event Type

Nuclear Power Plant

Source Term Options for Nuclear Power Pla

Source term based on reactor conditions

- Long Term Station Blackout (SDARCA)
- LOCA (NUREG-1465)
- Coolant Release Accidents
- Containment Radiation Monitor

Source term based on nuclide specific data

- Coolant Sample
- Containment Air Sample
- Effluent Releases - by Mixtures
- Effluent Release Rates - by Nuclide
- Effluent Release Concentrations - by Nuclide

Spent Fuel

Source Term Options for Spent Fuel

- Pool Storage - Uncovered Fuel
- Pool Storage - Damaged Assembly Underwater
- Dry Storage - Cask Release

Fuel Cycle

Source Term Options for Fuel Cycle Eve

- U₂F₆ Release from Cylinder(s)
- Fire Involving Uranium Oxide
- Criticality Accident
- Explosion Involving Uranium Oxide
- Effluent Release Rates - by Nuclide
- Effluent Release Concentrations - by Nuclide

Other Materials

Source Term Options for Other Rad Mat

- Effluent Release Rates - by Nuclide
- Effluent Release Concentrations - by Nuclide
- Sources and Material in a Fire

PICK A SOURCE TERM

For this scenario, the most appropriate model would be the LOCA model

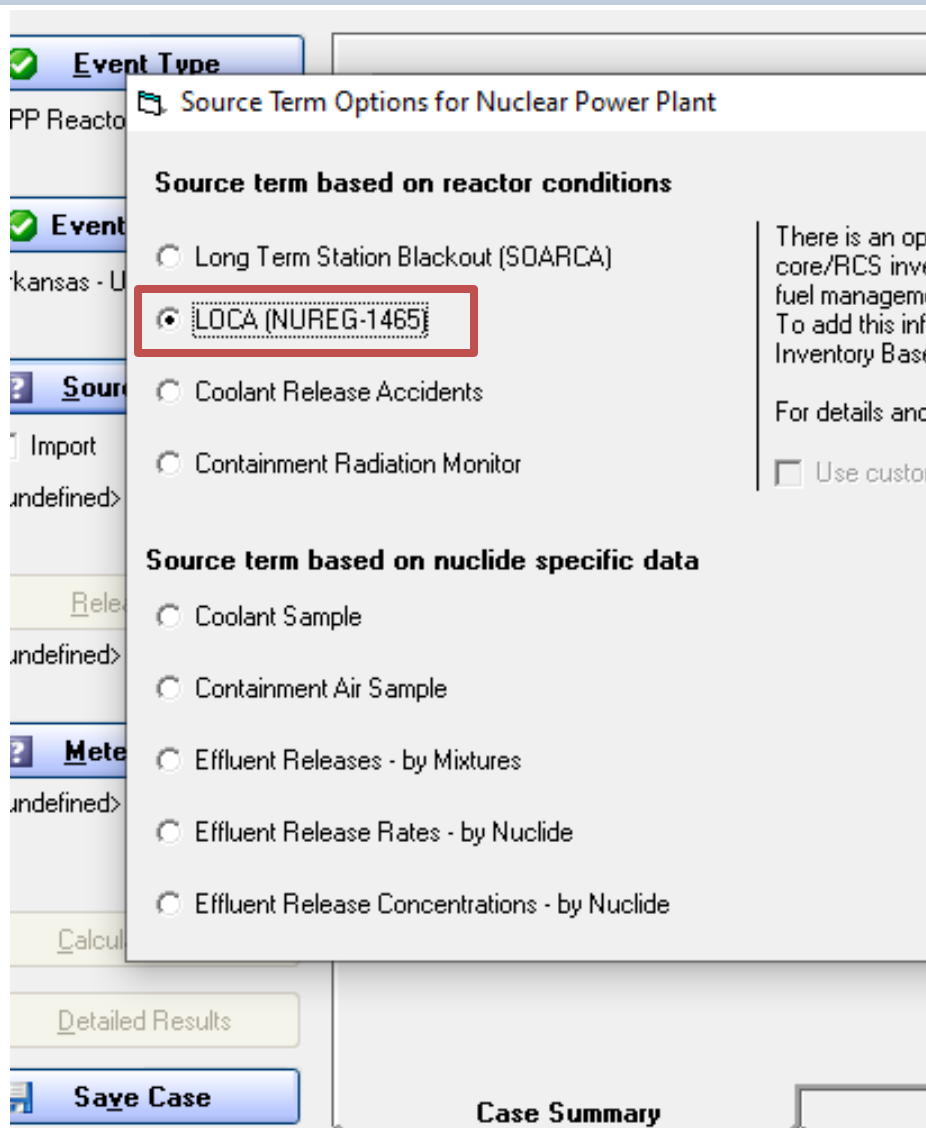

ENTER SOURCE TERM DETAILS

LOCA (NUREG-1465)

Reactor shutdown: 2026/01/27 08:00

Core uncovered: 2026/01/27 10:30

Method used for core damage estimate

Core recovered

Yes 2026/01/27 13:00

No

Specified damage amount

Cladding failure 100 percent

Core melt 100 percent

Vessel melt through

- Each model requires additional details like timing or measurements
- For the LOCA model:
 - Time of reactor shutdown
 - Starts the decay of all nuclides in the core (they're in equilibrium before)
 - Time core was uncovered
 - When NUREG-1465 models start, starting with 30 min of gap activity, then fuel melt
 - Is the core recovered?
 - Additional material stops being generated after the core becomes recovered
- All times entered with 24-hour clock

YOUR TURN TO USE RASCAL

- **Click Source Term**
- **Select Loss of Coolant Accident (LOCA)**
 - **Click OK**
- **Input timing sequence numbers**
 - **Shutdown Time - 0800**
 - **Time of Core Uncovery – 1030**
 - **Select Yes for Core Recovered, Time – 1300**
 - **Click OK**



LET'S WALK THROUGH TOGETHER



KNOWLEDGE CHECK



Why is it important to enter the reactor shutdown time?

- That is when the radionuclide decay calculation starts
- That is when the release starts
- That is when the damage to the reactor fuel begins

If the core is recovered, will there still be a release to the atmosphere?

- Maybe, it depends on the release pathway and leak rate
- Yes, that just stops further damage to the core
- No

AS YOU CAN SEE, THE CASE SUMMARY TAB UPDATES AS INFORMATION IS ADDED

As each step is completed, the input information is added to the case summary displayed.

The screenshot shows the 'Source Term to Dose - [New Case.STD]' application window. The interface includes a menu bar (File, Settings, Nuclide Data Viewer, Help) and a sidebar with five configuration steps: Event Type, Event Location, Source Term, Release Path, and Meteorology. The 'Case Summary' tab is active and displays the following information:

Case Summary	
Event Type	Nuclear Power Plant
Case description Available after calculations completed	
Location	
Name:	Beaver Valley - Unit 1
City, county, state:	Shippingport, Beaver, PA
Lat / Long / Elev:	40.6219° N, 80.4339° W, 205 n
Time zone:	Eastern
Population (2010):	2,706 / 12,904 / 111,190 (2 / 5)
Reactor Parameters	
Reactor power:	2900 MWt
Average burnup:	30000 MWd / MTU
Containment type:	PWR Subatmospheric
Containment volume:	1.80E+06 ft³
Design pressure:	54 lb/in²
Design leak rate:	0.10 %/d

NOW WE'LL LOOK AT RELEASE PATHWAY

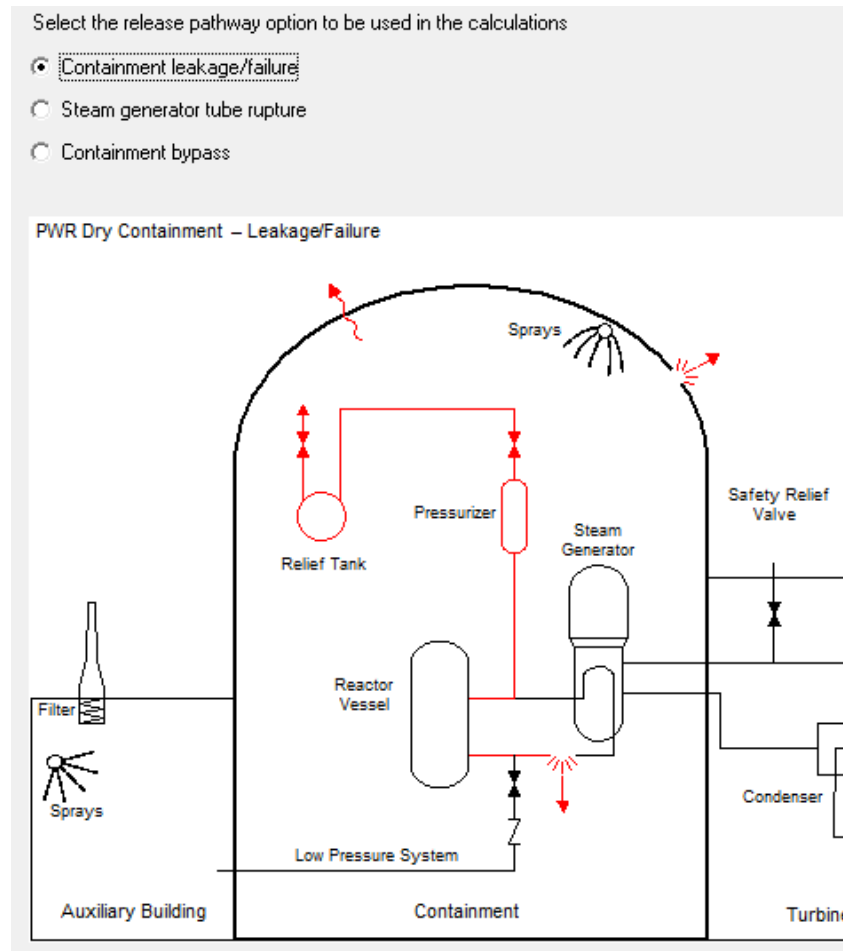

- RASCAL needs information on how generated material is released to the atmosphere
 - Pathway
 - Height
 - Wind speeds change with height
 - Reduction
 - Amount of material reduced by decay, holdup, filter, sprays
 - Timing
 - Release rates, start and stop
- We'll start by selecting the Pathway

FOR THIS RELEASE PATHWAY OPTION, WE'LL NEED TO INPUT:

PWR - Dry Containment Leakage or Failure

Pathway description: (optional: 60 characters)

Release height: (Stack height: 185 ft)

Release timings: Core uncovered: 2020/08/23 00:00

Leak rate to atmosphere described by: Percent volume / time
 Containment pressure / hole size

Date	Time	Event	Event setting
2020/08/23	00:00	Leak rate (% vol)	Design
2020/08/23	00:00	Sprays	Off

Don't copy this data. For discussion purposes only.

Add Row
Remove Row
Sort Rows
Clear All

- Release Height
 - 10m is minimum height allowed (ground release)
- Select leak rate type
 - Percent Volume / Time (e.g., 3%/hour)
 - Containment pressure / Hole Size (e.g., 30 psi/2 cm²)
- Define release timeline
 - Used for leak rate and additional conditions
 - Need to review/set initial conditions, then can add rows as needed

YOUR TURN TO USE RASCAL



- Click Release Path
- Select Containment leakage/failure, Click OK
- Ensure release height is set to 10m
- Change the initial leak rate (at 10:30) to 5% / day
- Keep sprays off
- Add row and enter:
 - Time: 18:00 Event Type = Leak rate Setting = 0.0 %/d
- Click OK

Time	Event	Event setting	
10:30	Leak rate (% vol)	Design	<input type="button" value="Add Row"/>
10:30	Sprays	Off	<input type="button" value="Remove Row"/>

LET'S WALK THROUGH TOGETHER



KNOWLEDGE CHECK



For a loss of coolant accident, RASCAL can model the release of material to the atmosphere via which of the following pathways? [select all that apply]

– Containment

– Steam generator

– Bypass of containment via other systems

– Direct from the reactor vessel

T or F, in RASCAL a release height of 10m is considered ground level?

– True

– False

MOVING ONTO METEOROLOGY

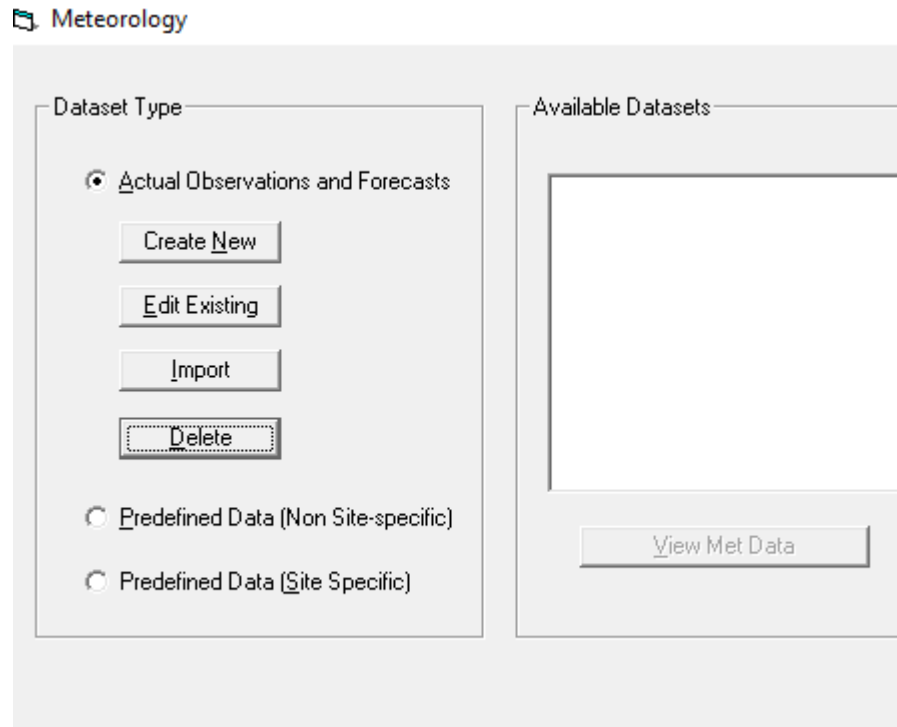

- Actual
 - Enter station observations/forecasts
 - Manual entry or internet download
- Pre-defined (non site-specific)
 - Simple static weather conditions
 - Easy/fast if no meteorological data known, but doesn't include topo/roughness
- Predefined (site-specific)
 - Allows custom creation of likely conditions

WE'LL MOSTLY USE ACTUAL FOR EXERCISES/EVENTS

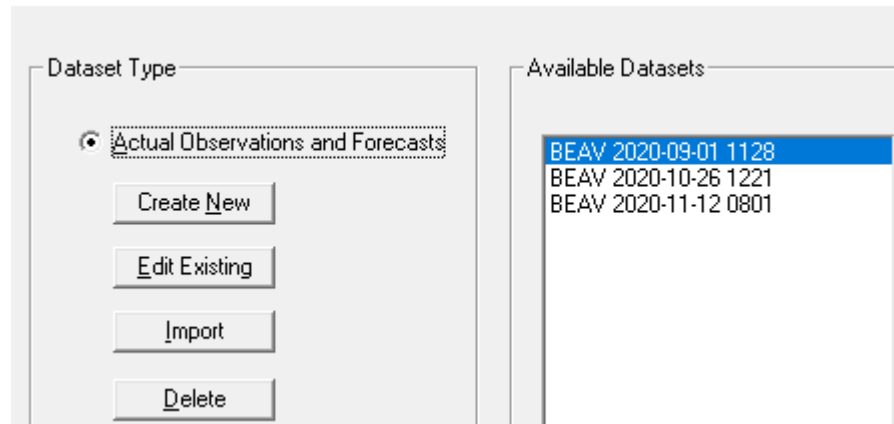
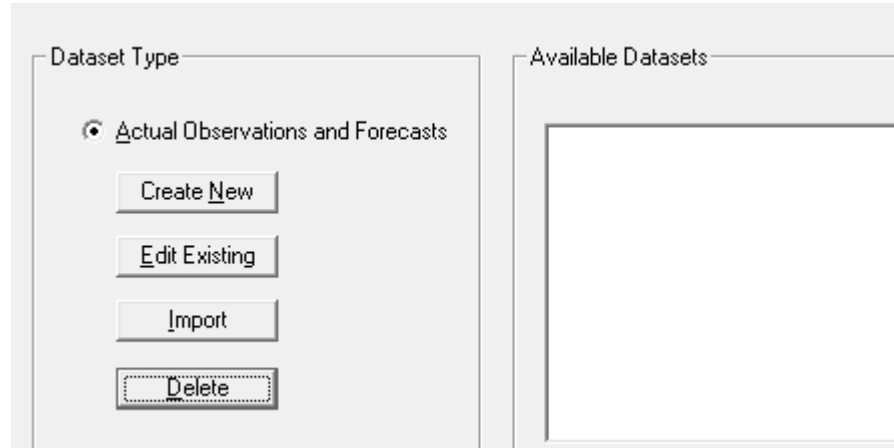

- We won't use pre-defined except in training
- For actual conditions, weather data is managed as site-dependent files
 - Create New / Edit
 - View any previously saved weather files
 - Usable as long as times support scenario

EACH SITE CONTAINS PREDEFINED WEATHER STATIONS

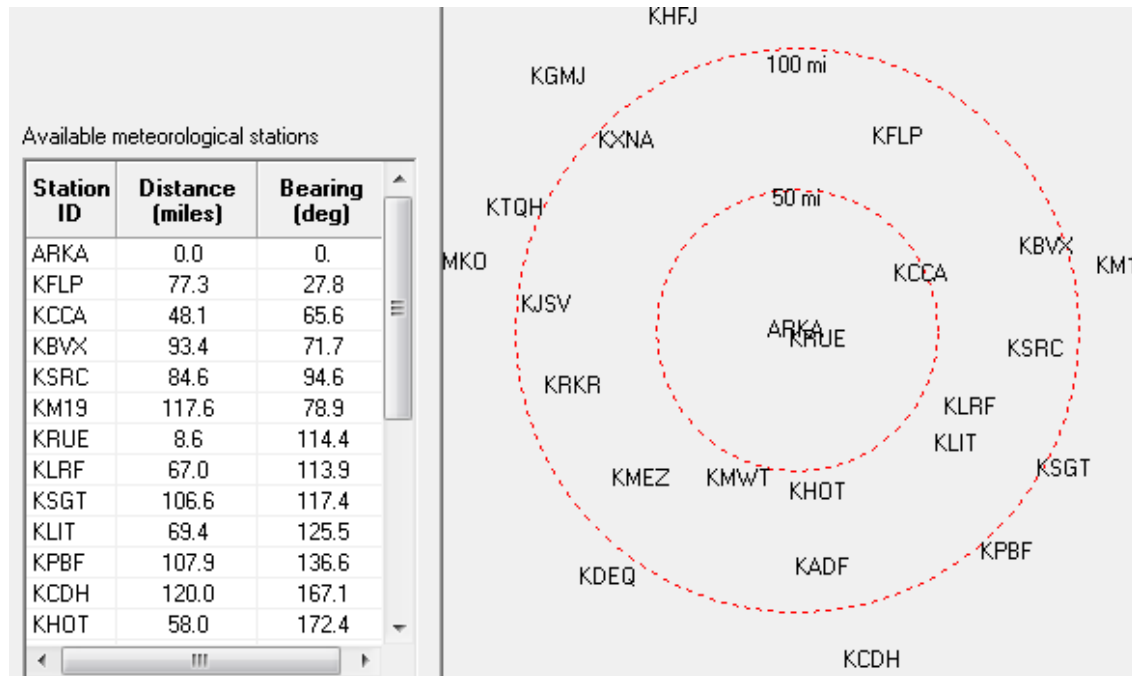

- Table and map show site and surrounding weather stations
- Select stations with plume direction in mind

INPUTTING WEATHER DATA

Station ID	Type	Date	Time (24 h)	Wind Direct from (deg)	Speed (mph)	Stability Class	Precipitation	Air * Temp (deg F)	Air * Pressure (mb)	Dew Pt * (deg F)
ARKA	Obs	2016/02/02	00:00							
KFLP										
KCCA										
KBVX										
KSRC										
KM19										
KDUE										

- Select weather station on the left to input its data on the right:
 - Type
 - Date/Time
 - Wind Direction/Speed
 - Stability
 - Precipitation

RASCAL USES OBSERVED AND/OR FORECAST WEATHER DATA

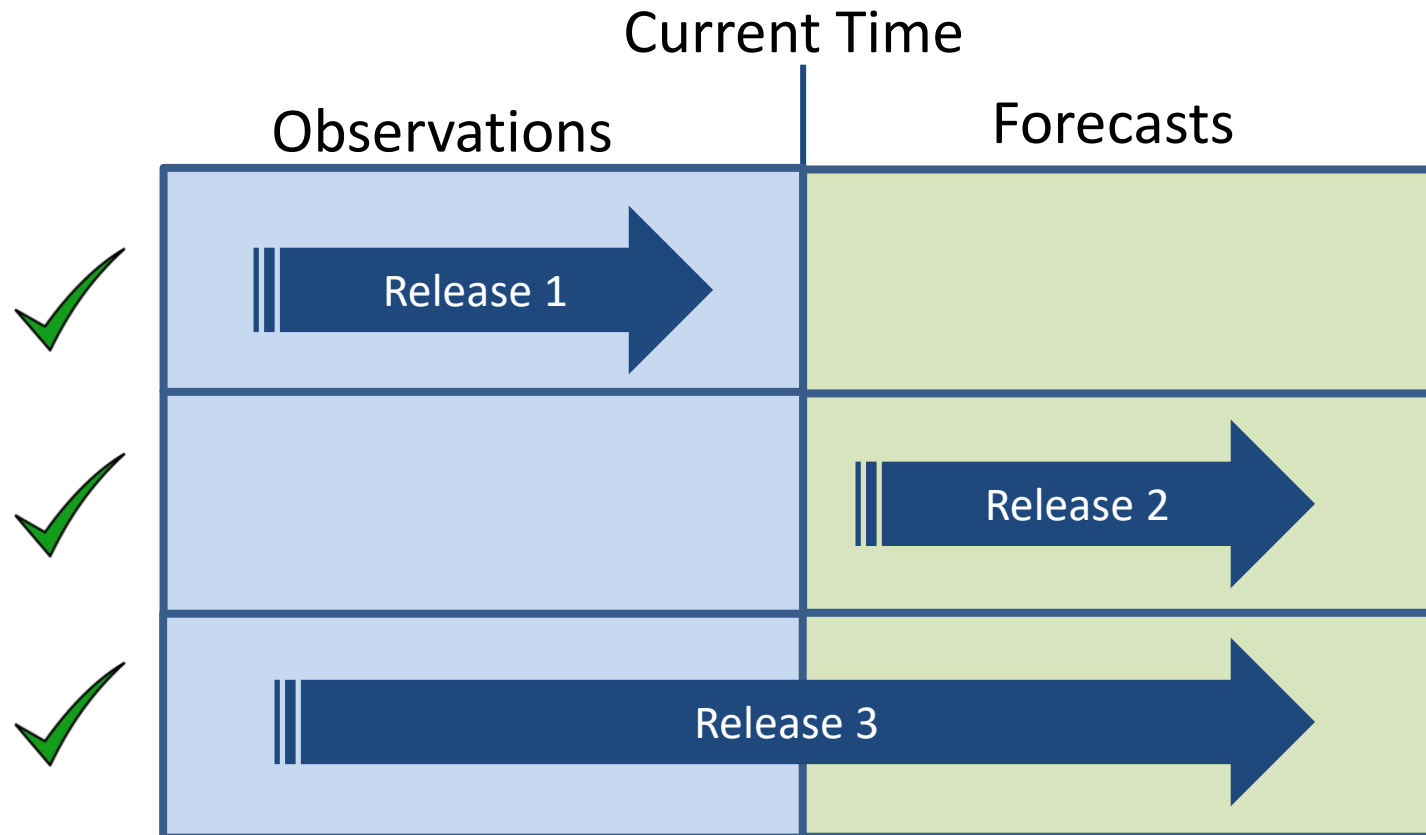

RASCAL can model releases in the past (all observations), in the future (all forecasts), or that span both.

RASCAL CAN RUN WITH A SINGLE WEATHER DATAPoint



However, the initial meteorological data must fall within 2 hours before the start of the release to the atmosphere. (Release starts at 10:30; must have some meteorology defined within the 8:30 to 10:30 window)

ALTHOUGH SINGLE DATAPOINT WEATHER IS POSSIBLE, MORE DATA IS PREFERRED

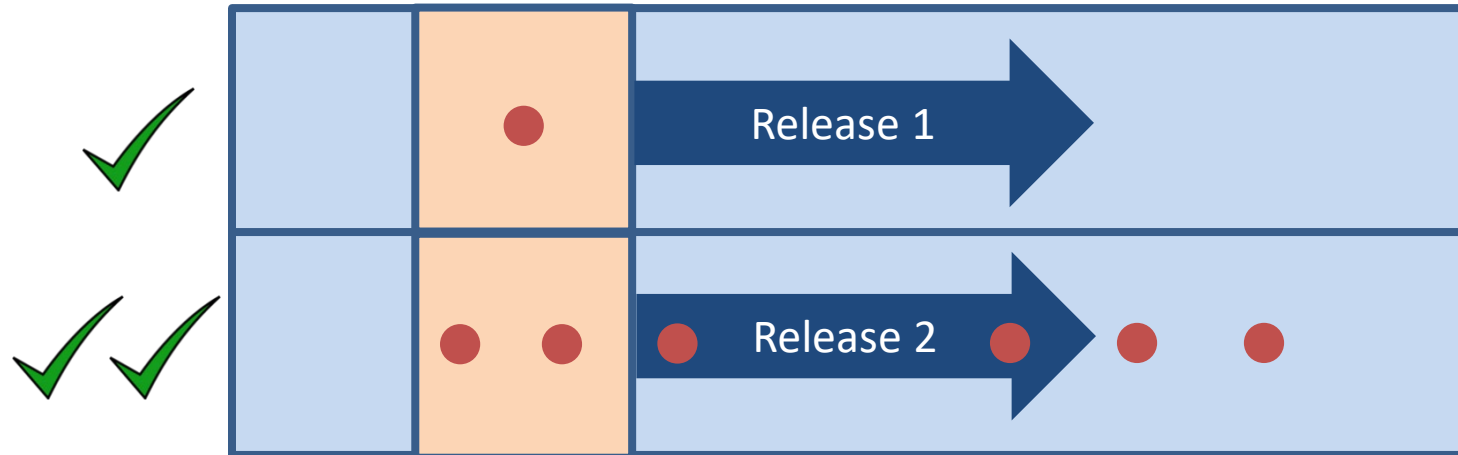

Important when the release may start in the future or may continue for some period of time. You will likely need both observed and forecast data.

However, our scenario doesn't have additional info like forecasts yet.

PROCESS DATA

File Stations Help

Location

 Enter Data

 Process Data

Return

Station ID	Number of Observations	First Observation	Last Observation
ARKA	2	2020/04/23 00:00	2020/04/26 00:00
KADF	0		
KBVX	0		
KCCA	0		
KCDH	0		
KDEQ	0		
KFLP	0		
KGMJ	0		
KHFJ	0		
KHOT	0		
KJSV	0		
KLIT	0		
KLRF	0		
KM19	0		
KMEZ	0		
KMKD	0		

Click Process Data to compile all the weather data into a form that the models can use.

RASCAL PROCESSES ALL ENTERED DATA INTO A MERGED GRIDDED FIELD THAT CHANGES OVER TIME

- This named file will show on the main met screen
- Weather details can be viewed if needed (View dataset)

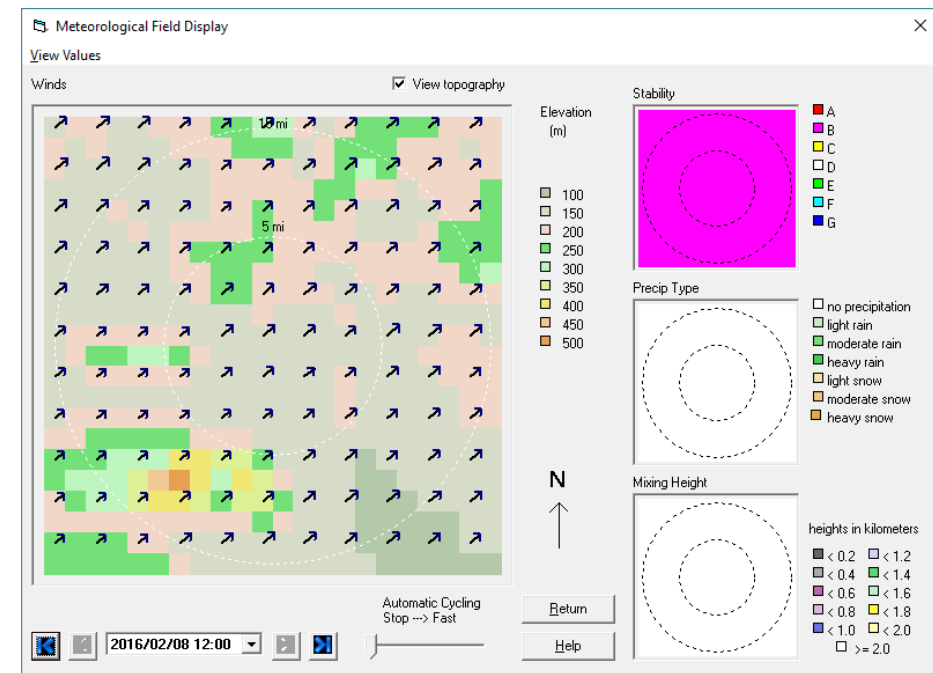
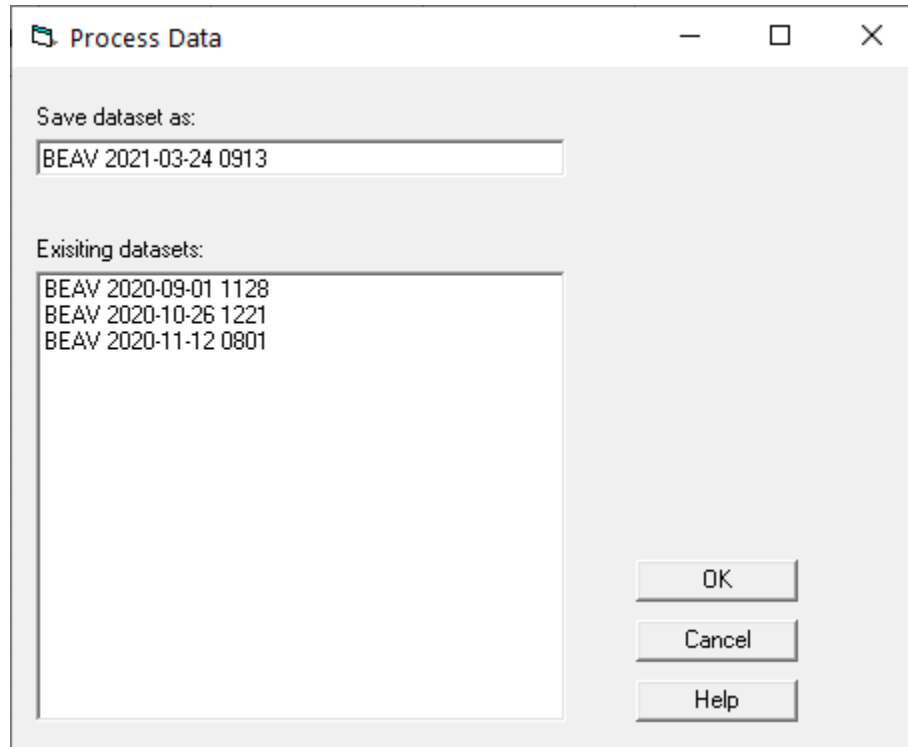

FINALLY, SELECT WHICH WEATHER FILE YOU WANT RASCAL TO USE

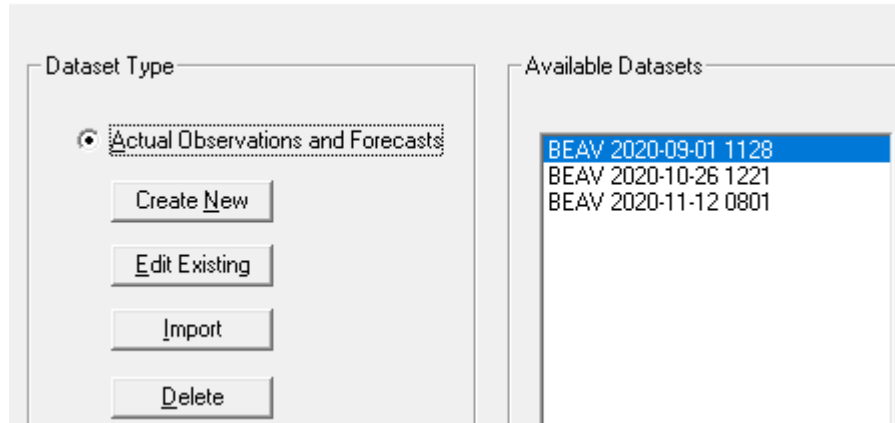

- RASCAL will return to the main Meteorology screen
- Highlight the desired weather data

YOUR TURN TO USE RASCAL

- Click Meteorology
- Select option for Actual Observations and Forecasts
 - Click Create New button
- Click Enter Data button
- For the BEAV station enter the following:
 - Time = 10:00
 - Winds = from 45 deg at 2 mph
 - Stability class = B
 - Precipitation = None
 - Click OK
- Click Process Data button then click OK
- Click the Return button
- Make sure your newly created file is selected in blue in the list of available datasets. Click OK



LET'S WALK THROUGH TOGETHER



KNOWLEDGE CHECK



T or F, pre-defined weather conditions are acceptable to use in a real event?

- True
- False

T or F, RASCAL requires at least some weather data to drive the ATD models?

- True
- False

T or F, RASCAL allows you to enter weather data that varies in both space and time?

- True
- False

T or F, RASCAL can model a release that may occur in the future?

- True
- False

CALCULATE DOSES

Specify options and title for this set of calculations, then OK to begin calculations.

Distance of calculation

Close-in + out to 10 miles (16 km)

Close-in + out to 25 miles (40 km)

Close-in + out to 50 miles (80 km)

Close-in + out to 100 miles (160 km)

Close-in only

Using close-in distances in miles:
0.1, 0.2, 0.3, 0.5, 0.7, 1.0, 1.5, 2.0

Defaults

User defined

Start of release to atmosphere:
2016/02/02 00:00 (from release pathway definition)

End calculations at

Start of release to atmosphere plus: hours

User specified time:

Inhalation dose coefficients to use in calculations

ICRP 26/30

ICRP 60/72

Case information

Title:

(required - max 45 characters)

Case description:

(optional - max 600 characters)

Analyst:

Dose Analyst

- Nothing has been calculated at this point
- With a few additional parameters, RASCAL will perform all its calculations

PICK A DISTANCE TO SET THE CALCULATION AREA

Specify options and title for this set of calculations, then OK to begin calculations.

Distance of calculation:

- Close-in + out to 10 miles (16 km)
- Close-in + out to 25 miles (40 km)
- Close-in + out to 50 miles (80 km)
- Close-in + out to 100 miles (160 km)
- Close-in only

Using close-in distances in miles:
0.1, 0.2, 0.3, 0.5, 0.7, 1.0, 1.5, 2.0

Defaults

User defined

Start of release to atmosphere:
2016/02/02 00:00 (from release pathway definition)

End calculations at:

- Start of release to atmosphere plus: 8 hours
- User specified time: 2016/02/02 08:00

Inhalation dose coefficients to use in calculations:

- ICRP 26/30
- ICRP 60/72

Case information:

Title:
(required - max 45 characters)

Case description:
(optional - max 600 characters)

Analyst:

- Dose Analyst
-

Help Cancel OK

- Shorter distances provide higher resolution
- Rule of Thumb – start on the 10 mile distance. If doses are high at the 10 mile edge, go to 25 miles

CLOSER CALC DISTANCES PROVIDE BETTER RESOLUTION IF YOU DON'T NEED TO SEE FURTHER OUT

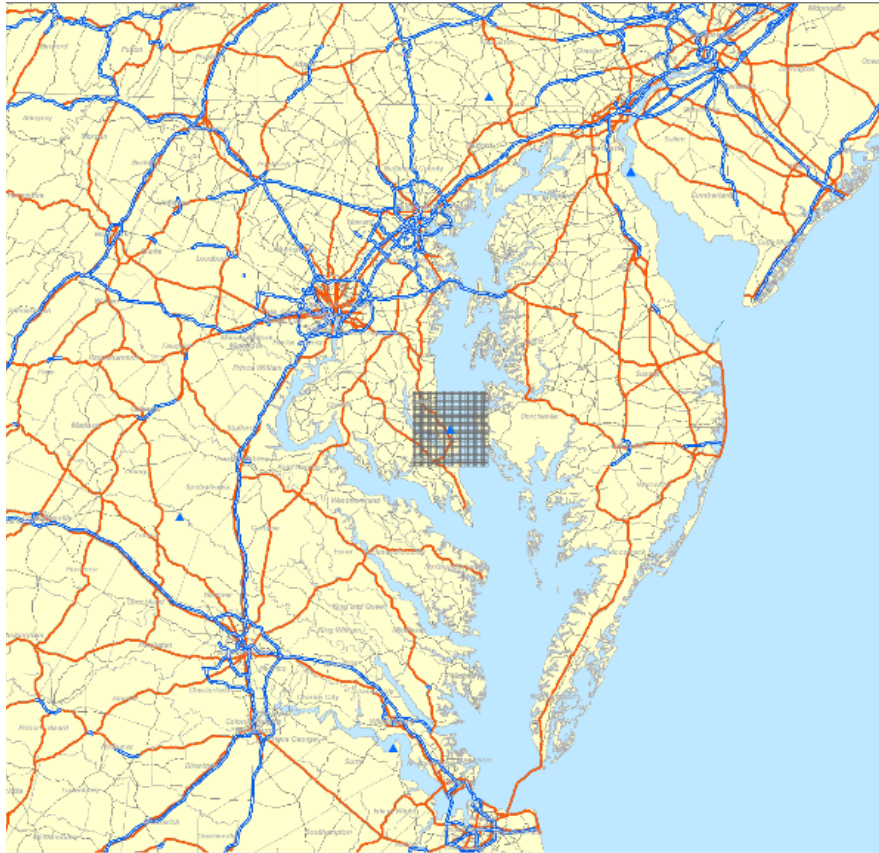

10 mile grid – cells are .5 mile wide

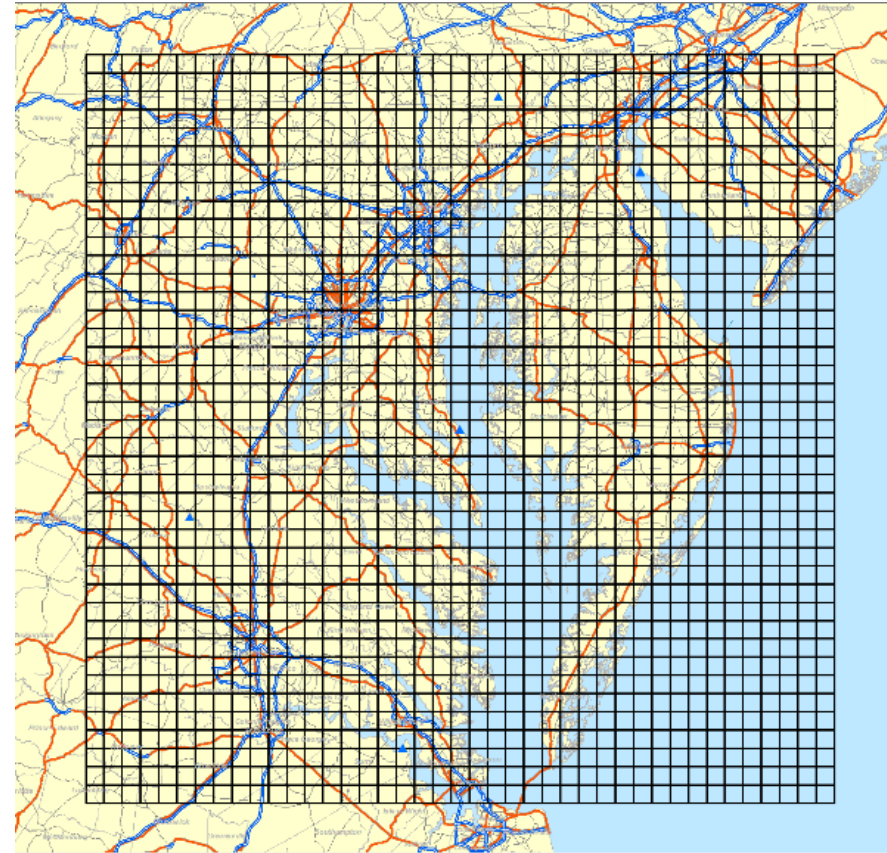

100 mile grid – cells are 5 miles wide

DEFINE A CALCULATION TIME

Specify options and title for this set of calculations, then OK to begin calculations.

Distance of calculation

Close-in + out to 10 miles (16 km)

Close-in + out to 25 miles (40 km)

Close-in + out to 50 miles (80 km)

Close-in + out to 100 miles (160 km)

Close-in only

Using close-in distances in miles:
0.1, 0.2, 0.3, 0.5, 0.7, 1.0, 1.5, 2.0

Defaults

User defined [Set Close Distances](#)

Start of release to atmosphere:
2016/02/02 00:00 (from release pathway definition)

End calculations at

Start of release to atmosphere plus: hours

User specified time:

Inhalation dose coefficients to use in calculations

ICRP 26/30

ICRP 60/72

Case information

Title:

(required - max 45 characters)

Case description:

(optional - max 600 characters)

Analyst:

Dose Analyst

[Help](#) [Cancel](#) [OK](#)

- Duration after the first release to atmosphere that RASCAL terminates the release, plume movement and dose calculations
- If time is set too short, dose may be missed; no disadvantage to going long (except runtime)

SET CALCULATION DURATION TO ALLOW FOR TRAILING PLUME EDGE TO REACH SET DISTANCE

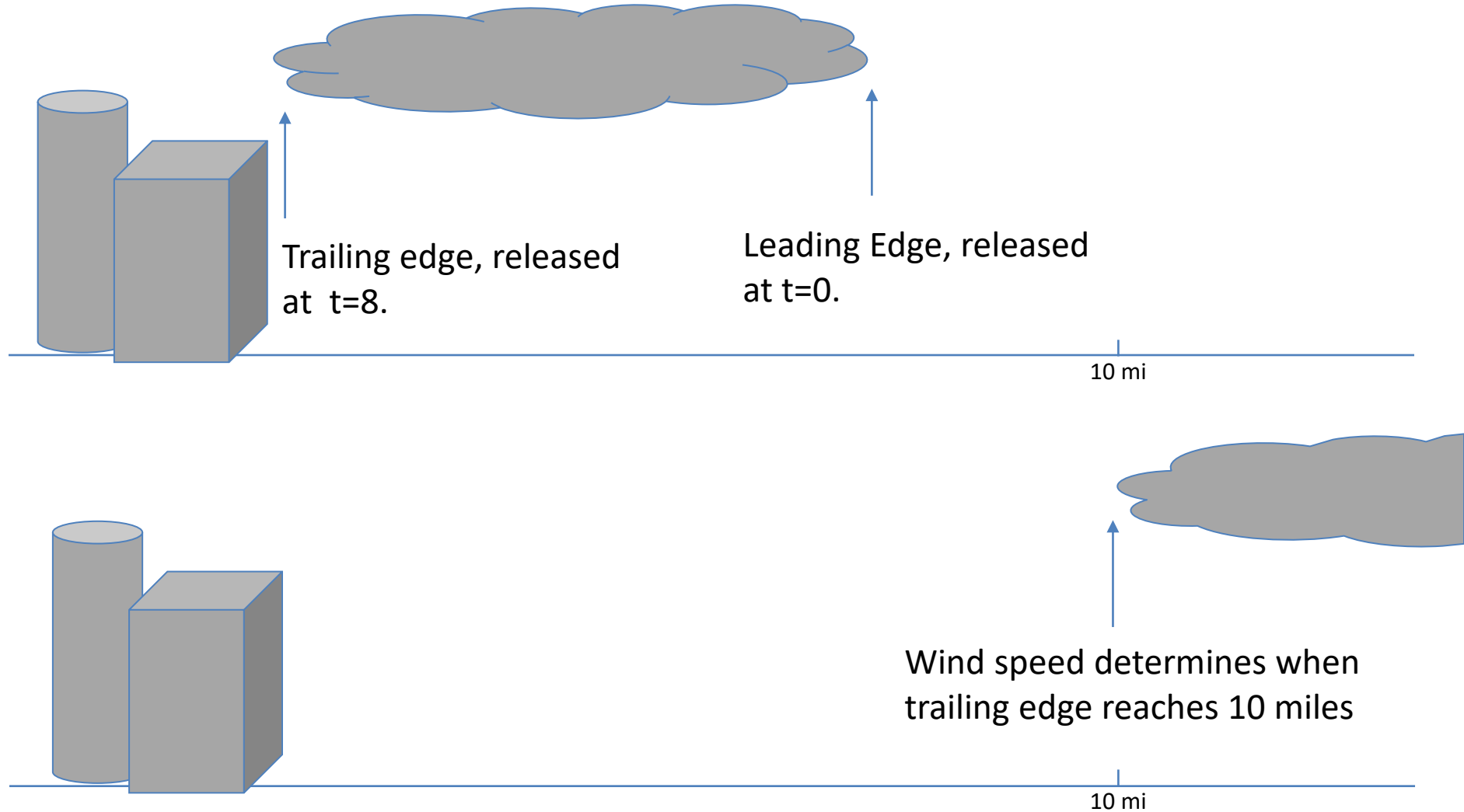

THERE IS A RULE-OF-THUMB FOR ESTIMATING THE CALCULATION DURATION

$$\text{Calculation Duration} \geq \left(\text{Release Duration} + \frac{\text{Calculation Distance}}{\text{Wind Speed}} \right) \times 1.1$$

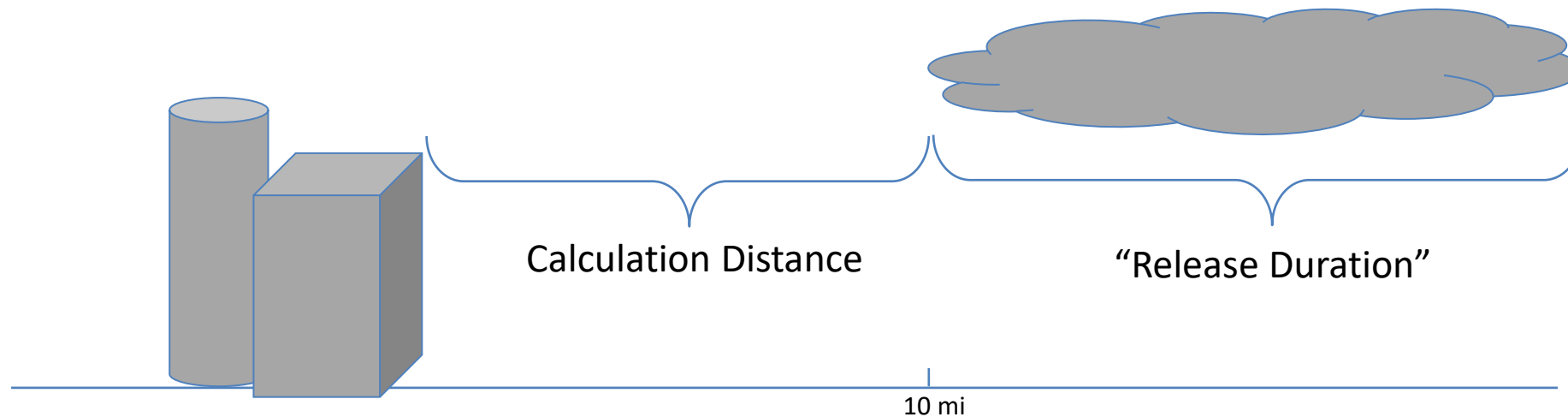

For our problem, 7.5 hr release with 2 mph winds, calculate a duration for a 10-mile grid.

7.5 hours + (10 miles / 2 mph) = 12.5 hours

Add 10% to get 13.75, then round up to the nearest hour (14)

SELECT THE INHALATION DOSE COEFFICIENTS TO BE USED

Specify options and title for this set of calculations, then OK to begin calculations.

Distance of calculation

Close-in + out to 10 miles (16 km)

Close-in + out to 25 miles (40 km)

Close-in + out to 50 miles (80 km)

Close-in + out to 100 miles (160 km)

Close-in only

Using close-in distances in miles:

0.1, 0.2, 0.3, 0.5, 0.7, 1.0, 1.5, 2.0

Defaults

User defined

Start of release to atmosphere:

2016/02/02 00:00 (from release pathway definition)

End calculations at

Start of release to atmosphere plus: hours

User specified time:

Inhalation dose coefficients to use in calculations

ICRP 26/30

ICRP 60/72

Case information

Title:

(required - max 45 characters)

Case description:

(optional - max 600 characters)

Analyst:

Dose Analyst

- ICRP 26/30 vs 60/72
- Currently, NRC and most States use 26/30
- New EPA PAG Manual uses 60/72
- Differences are inclusion of child thyroid CEDE and some minor dose values changes

ENTER THE CASE INFORMATION

Specify options and title for this set of calculations, then OK to begin calculations.

Distance of calculation

Close-in + out to 10 miles (16 km)

Close-in + out to 25 miles (40 km)

Close-in + out to 50 miles (80 km)

Close-in + out to 100 miles (160 km)

Close-in only

Using close-in distances in miles:

0.1, 0.2, 0.3, 0.5, 0.7, 1.0, 1.5, 2.0

Defaults

User defined

Start of release to atmosphere:

2016/02/02 00:00 (from release pathway definition)

End calculations at

Start of release to atmosphere plus: hours

User specified time:

Inhalation dose coefficients to use in calculations

ICRP 26/30

ICRP 60/72

Case information

Title:

(required - max 45 characters)

Case description:

(optional - max 600 characters)

Analyst:

Dose Analyst

Help Cancel OK

- RASCAL requires a case title
- Description used for justification or special notes; don't need to repeat case info
- Select and/or define an analyst name

WHAT HAPPENS WHEN THE OK BUTTON IS CLICKED?

- **RASCAL calculates the atmospheric source term and runs the ATD models with the given weather**
 - You cannot interrupt the calculations
- **Once complete, view results tabs at the bottom**
 - Case Summary
 - Source Term
 - Maximum Dose Values

YOUR TURN TO USE RASCAL



- **Click Calculate Doses**
- **Leave Distance of Calculation at 10 miles**
- **Set End Calculations at:**
 - **Start of release to atmosphere plus: 14h**

$$\textit{Calculation Duration} \geq \left(\textit{Release Duration} + \frac{\textit{Calculation Distance}}{\textit{Wind Speed}} \right) \times 1.1$$

- **Click OK to start the calculations**

LET'S WALK THROUGH TOGETHER



KNOWLEDGE CHECK



Which calculation grid has the better resolution?

- 50-mile
- 10-mile
- They have the same resolution

What would you set as the calculation duration with a 7-hour release with 5 mph winds on a 10-mile grid?

- 8 hours (RASCAL default)
- 9 hours
- 10 hours or more
- 96 hours (RASCAL max)

RASCAL RESULTS

Maximum Dose Values (rem) - To 10 mi

Dist from release miles (kilometers)	3 (4.8)	4 (6.4)	5 (8.0)	7 (11.3)	10 (16.1)
Total EDE	1.7E-01	1.6E-01	1.3E-01	9.8E-02	6.7E-02
Thyroid CDE	3.9E-02	3.5E-02	3.0E-02	2.2E-02	1.5E-02
Inhalation CEDE	1.4E-01	1.3E-01	1.1E-01	8.0E-02	5.6E-02
Cloudshine	***	***	***	***	***
4-day Groundshine	2.9E-02	2.8E-02	2.4E-02	1.8E-02	1.1E-02
Inter Phase 1st Yr	<u>2.3E+00</u>	<u>2.2E+00</u>	2.0E+00	1.4E+00	9.2E-01
Inter Phase 2nd Yr	<u>1.8E+00</u>	<u>1.7E+00</u>	<u>1.5E+00</u>	<u>1.1E+00</u>	<u>6.9E-01</u>

Notes:
• Inhalation dose coefficients used: ICRP 26/30
• Doses exceeding EPA PAGs are underlined.
• Early-Phase PAGs: TEDE - 1 rem, Thyroid (iodine) CDE - 5 rem
• Intermediate-Phase PAGs: 1st year - 2 rem, 2nd year - 0.5 rem
• *** indicates values less than 1 mrem

Value displayed: Close-in dose Doses to 10 miles Criticality shine dose
Display units: English Metric

Definitions Print

Case Summary Source Term **Maximum Dose Values**

- When RASCAL is finished calculating, it shows this screen, which is just 1 of 3 tabs at the bottom
- They each contain different information and have a different purpose, let's go through them

Your results will be different than screenshot.
For discussion purposes only.

CASE SUMMARY TAB SHOWS INPUTS

Case Summary

Event Type Nuclear Power Plant

Case description
None

Location
Name: Arkansas - Unit 1
City, county, state: Russellville, Pope, AR
Lat / Long / Elev: 35.3100° N, 93.2314° W, 103 m
Time zone: Central
Population (2010): 946 / 12,205 / 53,396 (2 / 5 / 10 mi)

Reactor Parameters
Reactor power: 2568 MWt
Average burnup: 30000 MWd / MTU
Containment type: PWR Dry Ambient
Containment volume: 2.09E+06 ft³
Design pressure: 59 lb/in²
Design leak rate: 0.20 %/d

Print

Case Summary Source Term Maximum Dose Values

- The Case Summary tab has been populating as we added info
- You can use it as a great way to check your inputs all at once or compare inputs against other dose assessors

Your results will be different than screenshot.
For discussion purposes only.

SOURCE TERM TAB SHOWS DETAILS FOR RELEASE TO ATMOSPHERE

Source Term

Summary of activity released to atmosphere

	Ci	% of total	
Noble gas	7.2E+03	66.7	Noble gas / I-131 ratio = No I-131
Iodines	0.0E+00	0.0	
Other	3.6E+03	33.3	
Total	1.1E+04	100.0	

List of all radionuclides released with total activity

Nuclide	Ci	Nuclide	Ci	Nuclide	Ci
Co-60	3.6E+03	Xe-133	7.2E+03		

Notes:
• Nuclides with * in name include implicit daughters.

Nuclides important to dose - top 10 by pathway with cumulative contribution

	Cloudshine		Inhalation		Groundshine	
1	Co-60	0.98	Co-60	1.00	Co-60	1.00
2	Xe-133	1.00				

Display units
 English
 Metric

View Balance View Importance Release vs. Time Print

Case Summary **Source Term** Maximum Dose Values

- Summary window
- View Balance
 - Where nuclides are at the end of the simulation
- View Importance
 - What nuclides are contributing the most to dose
- Release vs. Time
 - Displays amount of each nuclide released each 15 minute time step
 - Can be exported

Your results will be different than screenshot.
For discussion purposes only.

MAX VALUES TABLE SHOWS DOSE SNAPSHOT

Maximum Dose Values (rem) - To 10 mi

Dist from release miles (kilometers)	3 (4.8)	4 (6.4)	5 (8.0)	7 (11.3)	10 (16.1)
Total EDE	1.7E-01	1.6E-01	1.3E-01	9.8E-02	6.7E-02
Thyroid CDE	3.9E-02	3.5E-02	3.0E-02	2.2E-02	1.5E-02
Inhalation CEDE	1.4E-01	1.3E-01	1.1E-01	8.0E-02	5.6E-02
Cloudshine	***	***	***	***	***
4-day Groundshine	2.9E-02	2.8E-02	2.4E-02	1.8E-02	1.1E-02
Inter Phase 1st Yr	<u>2.3E+00</u>	<u>2.2E+00</u>	2.0E+00	1.4E+00	9.2E-01
Inter Phase 2nd Yr	<u>1.8E+00</u>	<u>1.7E+00</u>	<u>1.5E+00</u>	<u>1.1E+00</u>	<u>6.9E-01</u>

Notes:
• Inhalation dose coefficients used: ICRP 26/30
• Doses exceeding EPA PAGs are underlined.
• Early-Phase PAGs: TEDE - 1 rem, Thyroid (iodine) CDE - 5 rem
• Intermediate-Phase PAGs: 1st year - 2 rem, 2nd year - 0.5 rem
• *** indicates values less than 1 mrem

Value displayed: Close-in dose Doses to 10 miles Criticality shine dose
Display units: English Metric

Definitions Print

Case Summary Source Term **Maximum Dose Values**

- Summary window
 - Doses important for protective actions (TEDE, Thyroid)
 - Underlines doses exceeding PAGs
- Select distance
 - Close in vs selected “far out” model distance
- Does not show direction

Your results will be different than screenshot.
For discussion purposes only.

FOR ADDITIONAL RESULT INFORMATION, CLICK DETAILED RESULTS

Detailed Results of Dose Calculations

Result Type

- TED
- Inhalation CED
- Cloudshine Dose
- 4-Day Groundshine Dose
- External Gamma Exposure Rate (cloudshine + groundshine)
- External Gamma + Beta Exposure Rate
- Acute Bone Dose Total
- Acute Bone from Inhalation Only
- Acute Lung Dose
- Acute Colon Dose
- Thyroid CED
- Child Thyroid CED
- Groundshine Dose Over Defined Period
- Ground Concentration - Total
- Ground Concentration of: Am-241
- 1st year Intermediate Phase TED
- 2nd year Intermediate Phase TED
- 50 year Intermediate Phase TED
- I-131 Time-integrated Air Concentration

Time Period for Exposure

- Start of release to end of calculation
- Cumulative over interval
- From: 2018/05/11 00:00
- To: 2018/05/11 08:00
- Rate at single time
- 2018/05/11 08:00

Display Format

From 10-mile calculation

- Footprint
- Numeric table
- Special receptors
- Define Receptors

From close-in calculation

- Footprint
- Numeric table

Display Units

- English
- SI

Display Result

Help

Exit

- Provides additional graphical and tabular outputs
- Result types at top
 - Dose-related
 - Deposition/Measurements
 - Acute doses
- Settings on the bottom
 - Time - cumulative or rate
 - Map/Table; Close-in or Further Out
 - Units

DIFFERENCE BETWEEN FOOTPRINT AND TABLE

- Footprint provides celled results on map
- Table provides numeric values
- Both can be exported, map can be queried, table can be filtered

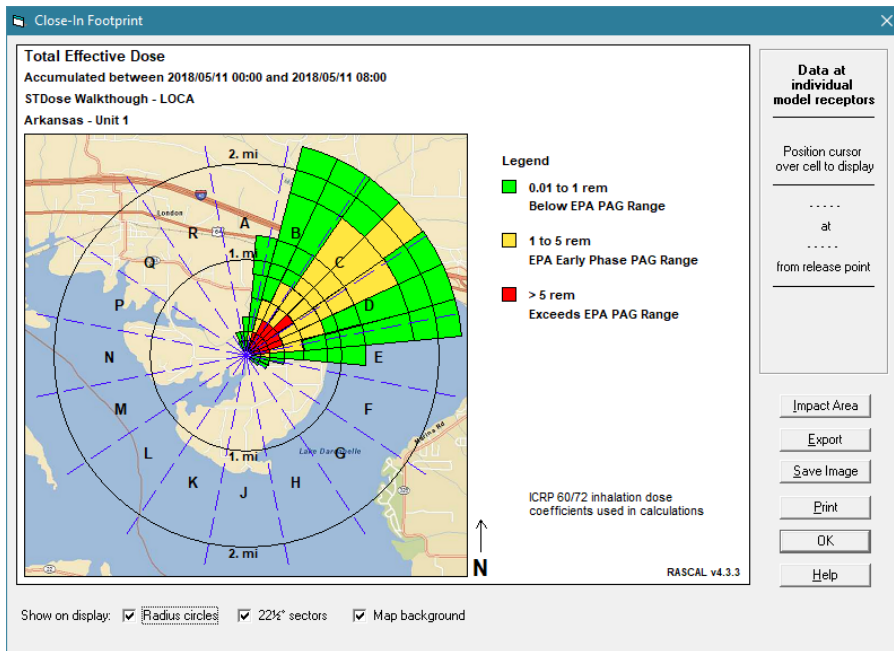

Footprint

Close-In Numeric Table

Total Effective Dose (rem)
Accumulated between 2018/05/11 00:00 and 2018/05/11 08:00

ICRP 60/72 inhalation dose coefficients used in calculations

Distance		Bearing from release point										
mi	km	10°	20°	30°	40°	50°	60°	70°	80°	90°	100°	110°
0.10	0.16	4.36E+00	1.80E+01	3.86E+01	5.66E+01	6.36E+01	5.66E+01	3.86E+01	1.80E+01	4.36E+00	3.56E-01	8.35E-02
0.20	0.32	1.19E+00	5.43E+00	1.25E+01	1.91E+01	2.17E+01	1.91E+01	1.25E+01	5.43E+00	1.19E+00	9.32E-02	2.40E-02
0.30	0.48	5.41E-01	2.72E+00	6.72E+00	1.06E+01	1.23E+01	1.06E+01	6.72E+00	2.72E+00	5.41E-01	3.26E-02	6.50E-03
0.50	0.80	1.69E-01	1.05E+00	2.91E+00	4.99E+00	5.88E+00	4.99E+00	2.91E+00	1.05E+00	1.69E-01	8.51E-03	8.82E-04
0.70	1.13	6.55E-02	4.96E-01	1.59E+00	2.97E+00	3.60E+00	2.97E+00	1.59E+00	4.96E-01	6.55E-02	2.01E-03	2.04E-04
1.00	1.61	1.73E-02	1.86E-01	7.65E-01	1.66E+00	2.12E+00	1.66E+00	7.65E-01	1.86E-01	1.73E-02	3.18E-04	1.31E-05
1.50	2.41	2.35E-03	4.90E-02	3.39E-01	1.01E+00	1.44E+00	1.01E+00	3.39E-01	4.90E-02	2.35E-03	1.60E-05	6.31E-07
2.00	3.22	3.01E-04	1.39E-02	1.74E-01	7.43E-01	1.19E+00	7.43E-01	1.74E-01	1.39E-02	3.01E-04	1.20E-07	...

Color all cells with a value equal to or greater than: 0.0

Dose rate vs time plot not available for this result type

Export
Print
Clear Color
OK
Help

Table

DIFFERENCE BETWEEN “CLOSE IN” AND “FAR OUT”

Two ATD models are used in the calculations

- Resolution advantages
- Overlap may not line up exactly

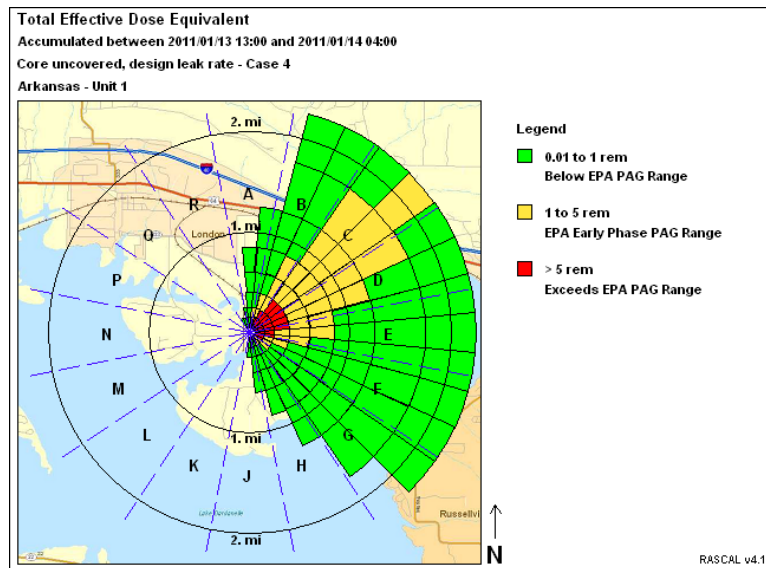

Plume Model

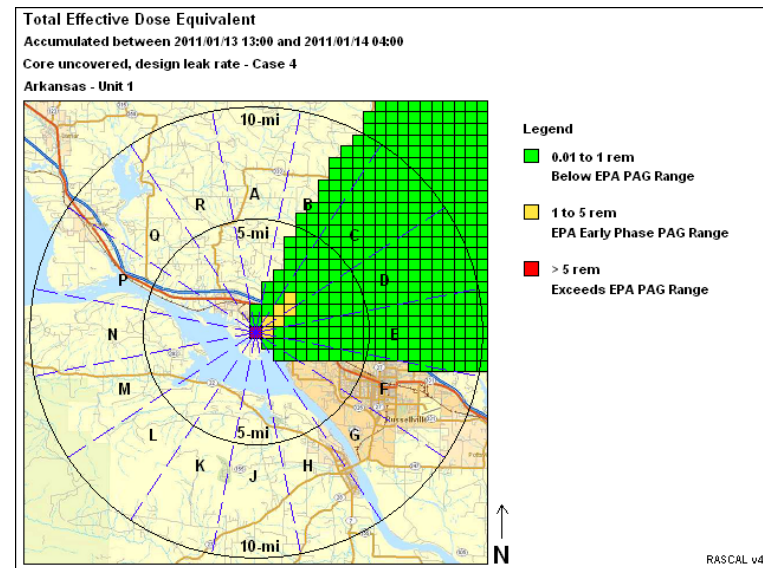

Puff Model

YOUR TURN TO USE RASCAL

- **Examine the results**
 - **Maximum Dose Values tab shows some doses at selected distances**
 - **Source Term tab show details about the atmospheric release**
 - **Click Details Results to see options for looking at dose on a map**



LET'S WALK THROUGH TOGETHER



KNOWLEDGE CHECK



What is the projected TEDE (rem) at 5 miles?

- 1.4E+00
- 1.7E+00
- 3.2E+01
- None of the above values

What percentage of the release to the atmosphere is iodines?

- 0.6%
- 12.9%
- 16.4%
- None of the above values

What direction is the plume projected to travel?

- Northeast
- East
- Southeast
- Southwest

THIS CONCLUDES OUR INTRO WALKTHROUGH

You should now be able to click through RASCAL start to finish.

Remember that resources & training can be found at:

<https://ramp.nrc-gateway.gov/>

If time allows, you can begin setup for internet download meteorology